

---

**Town of Mineral Springs  
Mineral Springs Town Hall  
3506 S Potter Road ~ Mineral Springs  
Town Council  
Regular Meeting  
November 12, 2015 ~ 7:30 PM**

---

---

**Agenda**

---

**1. Opening**

The meeting will be called to order, an invocation will be delivered and the Pledge of Allegiance will be recited.

**2. Public Comments**

The town council will hear comments from members of the public on any matters of interest to them during this ten-minute period.

**3. Consent Agenda**

- A. October 8, 2015 Regular Meeting Minutes
- B. September 2015 Tax Collector's Report
- C. September 2015 Finance Report

**4. Downtown Park Update**

The council will be updated on the status of the park construction process and will consider any further actions if required.

**5. Greenway Violations Update**

Zoning Administration Vicky Brooks will update the council on the status of the greenway violations issued by Union County Building Inspections. Council may consider any necessary actions if needed.

**6. Consideration of the 2016 Town Hall Holiday Schedule**

The council will consider approving the 2016 Town Hall Holiday Schedule as proposed.

**7. Consideration of Closing Town Hall the Week of Christmas 2015**

The council will consider whether or not to close town hall for the week of Christmas 2015; the deputy town clerk has volunteered to work Monday and Tuesday of that week should the council opt not to close.

**8. Staff Updates**

The staff will update the council on any developments that may affect the town.

**9. Other Business**

**10. Adjournment**

Town of Mineral Springs  
Town Hall  
3506 S. Potter Road  
Town Council  
Regular Meeting  
October 8, 2015 ~ 7:30 PM

Recessed at 8:57 p.m. and continued on  
October 15, 2015 at 7:30 p.m.

---

**Minutes Draft**

---

The Town Council of the Town of Mineral Springs, North Carolina, met in Regular Session at the Mineral Springs Town Hall, Mineral Springs, North Carolina, at 7:30 p.m. on Thursday, October 8, 2015.

**Present:** Mayor Frederick Becker III, Mayor Pro Tem Janet Critz, Councilwoman Valerie Coffey, Councilman Jerry Countryman, Councilwoman Lundeen Cureton, Councilwoman Peggy Neill, Town Clerk/Zoning Administrator Vicky Brooks, Attorney Bobby Griffin and Deputy Town Clerk/Tax Collector Janet Ridings.

**Absent:** None.

**Visitors:** Nickolas Amadio, Dan Blackman, Anna Plyler-Fitch, Don Gaddy, Bill Howie, Tim McCulla and Evan Wunder.

With a quorum present Mayor Frederick Becker called the Regular Town Council Meeting of October 8, 2015 to order at 7:30 p.m.

1. **Opening**

- Councilman Countryman delivered the invocation.
- Nickolas Amadio and Evan Wunder led the Pledge of Allegiance.

2. **Public Comments**

- Don Gaddy – Mineral Springs Volunteer Fire and Rescue Department.
- Anna Plyler-Fitch – 3118 Potter Road South.
- Bill Howie – Pleasant Grove Road.

3. **Consent Agenda**

- **Councilwoman Coffey** made a ***motion*** to approve the consent agenda containing the following:
  - A. *September 10, 2015 Regular Meeting Minutes and September 19, 2015 Special Meeting Minutes*
  - B. *August 2015 Tax Collector's Report*
  - C. *Tax Releases*
  - D. *August 2015 Finance Report*

and **Councilwoman Cureton** seconded. The motion passed unanimously as follows:

Ayes: Coffey, Countryman, Critz, Cureton and Neill

Nays: None

**4. Downtown Park Update and Bid Review**

- Mayor Becker announced that we did have our bid opening on October 1, 2015 and the information on the two bids that were received was in the agenda packet. The bids were a little bit above our budget “to say the least”. Mayor Becker explained that Mr. Dan Blackman [from Stewart, Inc.] has been working with the low bidder trying to get some insight.
- Mr. Blackman recapped that the bid announcements went into the Charlotte Observer and the Enquirer-Journal, there was a mandatory pre-bid meeting on September 17, 2015 (so that only the contractors that showed up were able to provide a bid), two contractors showed up (H.C. Rummage and McCollum Trucking and Grading), both submitted a bid and both were qualified, the licenses were vetted through, all paperwork was available, on the permit side – we have just a few minor comments left with the county and encroachment agreements with NCDOT are close at hand. We do have an apparent low bidder in H.C. Rummage, Inc. at \$169,800. Mr. Blackman recognized that this is over our allotted budget and asked the council how we might approach it. Mr. Blackman offered that he would explain some of the things that he found in discussion with the low bidder; however, he didn’t want to get into too many details, because he hasn’t provided them and we don’t have them under contract, but we have been trying to work through to make sure that Mr. Rummage does understand the project fully and that he understood which items were to be owner provided and which items were to be performed by the contractor. Mr. Blackman reminded the council that we also have a separate bid process for the playground (to try and save some money there). Mr. Rummage understands all of the project; they have gone through it front to back and his bid prices seem justified. Mr. Blackman stated “we were quite a bit shocked”; we knew our estimates stopped just short of the final set of plans going out and that there were going to be a few extra items that were going to raise the cost. Permitting required us to add an electrical line to heat the back flow preventer at the street, which ran utilities all the way from the back of the property to the front of the property. There was also the placing and removing the construction access. We did find that the largest discrepancies (differences between the early estimate and what was contractor provided) were with the grading, electrical and plumbing. Mr. Blackman stated that they do feel like these are valid numbers and there are no duplications; it is covering the entire scope of the project. As the mayor had mentioned, Mr. Blackman has been in discussion with the contractor and they do think there is one item that he has been able to help us through that clarification process by reducing the cost by \$5,000, which is not a large amount or enough to get us back to what the original allotted budget was.
- Mr. Blackman had a couple of questions for the council: What is the desire of the council at this point, and then with the answer to that question it will be to see if there is a recommendation to move forward with the contractor.

- Following are the questions and answers on this topic:
  - The plumbing and electrical are from the same company with both contractors?
    - ◆ *Correct.*
  - Are the prices identical for those particular items?
    - ◆ *Correct.*
  - The benefit (lesser price) is coming from the grading itself?
    - ◆ *That is hard to nail down, but yes there are general conditions; there are taxes on top of labor and a lot of things that are buried in there. It isn't that simple, because there are carpenters and a total of seven or eight subcontractors (three of which are grading, plumbing and electrical).*
  - Obviously the plumbing and electrical are companies that are utilized heavily in this area?
    - ◆ *The low bidder informed Mr. Blackman that he did get two bids and his two low bids were those subs that are listed.*
    - ◆ *Mayor Becker added that there was a plumber and electrical contractor who bid higher; the bid is based on the low bids received from plumbers and electricians.*
  - Neither the Union Chamber of Commerce nor the Better Business Bureau has ever heard of H.C. Rummage, Inc. Councilwoman Coffey was not in favor of the lowest bidder based on the lack of information she received on them.
    - ◆ *Mr. Blackman worked with H.C. Rummage more than 10 years ago; he did know through discussion that the two contractors were talking to each other after the pre-bid meeting and Mr. Rummage mentioned that he was in business for over 30 years. Mr. Blackman asked to not be quoted on that.*
    - ◆ *Mayor Becker added that the reason you don't see H.C. Rummage in consumer orientated places (like BBB or the Chamber) is that they are a wholesale business-to-business type contractor; they are seen as the site work (i.e. shopping centers).*
    - ◆ *Attorney Griffin added that he knows that H. Clark Rummage has been around since he has been in Monroe (1967) and that they have done a tremendous amount of construction work and building work. It is the council's job to award to the lowest responsible bidder; first they listen to the fellow that is in charge and his recommendation and then if they want to find that somebody is not responsible they are going to have to have good reasons for it other than not being on the internet.*
  - After a discussion on the lack of information available about H.C. Rummage with the Better Business Bureau and the Chamber it was noted that additional information (some history of their projects) should be shared with the council.
    - ◆ *Mr. Blackman will ask Mr. Rummage for a firm profile and references. Mr. Blackman will also check with the State General Licensing Board.*
  - Is there any further option to reduce the price?
    - ◆ *It would be a matter of reducing items on the contractor's responsibility (i.e. landscaping, removing the trellis). At the end of the day, Mr. Blackman did*

*not think they were going to get to a point that they are back down to the original amount.*

- ♦ *It was noted that Councilwoman Coffey was not saying they should reduce anything that they have planned, but she wanted to know if there was an option for the town to find a way to raise the money to pay for it, because this is what the town has presented, this is what they told the town was coming and this is what should come to fruition.*
  
- *If the council tables this until next month to await the information from Mr. Blackman what kind of delay for breaking ground will that create?*
  - ♦ *It would push us back to December, so it would be January, February and March.*
  - ♦ *Attorney Griffin offered that the council could continue this meeting.*
  - ♦ *Rather than waiting an entire month, the council will continue this meeting to next Thursday evening in an effort to not delay starting the project any further, which could compromise the plants' ability to get roots developed in time.*
  
- *Why is there such a divergence between what the council originally discussed and where Mr. Blackman thought the bid was going to be and what it ended up being?*
  - ♦ *The estimate was prepared without the final 100% set of plans, so there were a few items that were added in at the last meeting (including utilities).*
  - ♦ *The permitting process has required adding an electric outlet.*
  - ♦ *Construction costs are very high right now. The estimates were based on six month old data and things are increasing. A lot of people are very busy right now and they are finding that it is a contractors' market.*
  - ♦ *Mr. Blackman gave an anecdote (which doesn't totally apply to this particular situation) of Mecklenburg County Park projects that are being lumped together, such as three projects all in one that would normally have been twice this budget that would have brought in a certain level of contractor who could handle that type of work. Now those contractors are few and far between, so they have to lump three or four projects together to make them large enough so that the large contractors can bid. In many cases they are not getting enough bidders. The contracting companies have gotten so large that they are only doing very large projects. Mr. Blackman did send the notice to some of the contractors that he has worked with in the past to let them know there was an advertisement in the newspaper and one of them actually got back with him and said they are no longer doing public work, because there is so much money to be made in private work. They are seeing it across the board in various facets where contractors are in a position right now to be able to hold all the cards; it really is a difficult situation.*
  - ♦ *There will be seven or eight subcontractors on 4/10<sup>ths</sup> of an acre of property and there are costs involved with overseeing and scheduling all of those subs. When you work on a larger piece of property with a bigger project (i.e. multiple family housing unit) those initial getting-started costs and those mobilization costs begin to be smaller proportions of your overall budget. On a smaller project it's a little harder hit on startup costs.*

- The original budget was in the \$135,000 range.
  - ◆ *The budget for construction was \$100,000 and now it is \$160,000 not including the playground, which is \$39,600. The playground is a very specific bid from a specific vendor and that is a firm price.*
  - ◆ *We are going from \$130,000 turnkey (including Mr. Blackman's fee, the playground and the general contractor) to as much as \$240,000 if you add a little bit more in for contingency and our new bricks.*
  - ◆ *We are funding this project with a Capital Project Ordinance (currently it is \$127,000), which is funded with General Fund balance, so we are not earmarking a tax increase; we are using "cash on hand". The General Fund balance is the town's savings account. A Capital Project Ordinance allocates the cost of a project and that money would be transferred (as needed) from the General Fund into the Capital Project Fund and then paid to the contractor. The town currently has approximately \$700,000 in available fund balance to be used for whatever we want to use it for, so we have money available without borrowing money and without raising taxes. This will reprioritize our Capital Project schedule. If the town is going to spend \$100,000 more on this project, then for the next project (i.e. community center) we will probably want to wait on that until we have amassed an additional \$100,000. The good news (from a taxpayer standpoint) we've got the money in the bank even with the increased cost if the council feels that the public is entitled to get this project delivered. The bad news is that it is taking \$100,000 out of the fund balance, which is being saved and built up for the next project. Our revenues exceed our expenditures by approximately \$100,000 on a regular basis, so it is about a year's worth of savings, so it could slow down the upcoming project as much as a year if we transfer that additional \$105,000 out of the General Fund into this project. The money is there to be spent without borrowing and without a tax increase.*
  
- Which is the most important project: the one on the table now or the one down the road?
  - ◆ *According to the survey there was a huge response from people that wanted this type of park downtown.*
  
- At 7:34 p.m. on Thursday, October 15, 2015, Mayor Becker called the Thursday, October 8, 2015 meeting to order and the council continued their discussion on the Downtown Park Update and Bid Review.
- Mr. Blackman explained that he sent along qualifications and references from Mr. Rummage and he provided those just after the meeting last week. There are a few outstanding items: they are still working on final permits and there are a few more comments from the county that have to be addressed. Ms. Brooks confirmed that the NCDOT permits were in her possession.
- Councilwoman Cureton shared that she was glad that Councilwoman Coffey did what she did, because when they were building a church and they "did not check that man out good" they lost about \$35,000, so it was a good that she did that.
- Councilwoman Coffey thanked Mr. Blackman for the information; it is in order. Councilwoman Coffey has spoken with people since then and apologized that she

didn't have the information earlier, which caused this meeting tonight. Time is very valuable, so Councilwoman Coffey wanted to thank Mr. Blackman personally and thank everybody for their patience with her as well. Councilwoman Neill mentioned that H.C. Rummage did some work at her church, Siler Presbyterian, which she had been unaware of last week; they turned a three bedroom, two bath house into an office/conference room and they did a fabulous job.

- Mayor Becker pointed out that we don't have the final written contract, but the council could approve an amount in principle, subject to the attorney's approval of the actual wording of the contract, which is probably the standard AIA contract. Mr. Blackman responded that the contract was in the manual that the bidders received. Mayor Becker asked if that would be the one we would be following (with the boiler plate language). Mr. Blackman responded that they would adjust the amounts. Mayor Becker continued that the council needs to approve the amount. In an effort to facilitate this process, Mayor Becker drew up an amended Capital Project Ordinance for the council; he took the \$164,000 minus the \$5,000 (for not tearing up all the grass and having to replace all of that), putting the separate amount for purchasing the bricks, the design fee, the playground and then added \$5,700 for contingency if something else comes up with these county problems, we have to buy the fountain, so we've got a little bit of funding in place to do that. Mayor Becker stated that he was recommending that the council adopt the amended Capital Project Ordinance if they want to approve the amount in principle subject to the attorney's approval of that standard-form contract. Councilwoman Critz stated that she wanted to go on record saying that she appreciated the extra information.
- **Councilwoman Coffey** made a **motion** that the council approve the contract with H.C. Rummage pending all notification that needs to come, compliant with our attorney's and the language that needs to be utilized in it. Mayor Becker added that would be for that base amount and Councilwoman Coffey concurred \$164,800. **Councilwoman Neill** seconded the motion. The motion passed unanimously as follows:

*Ayes: Coffey, Countryman, Critz, Cureton and Neill*

*Nays: None*

- Mayor Becker asked that the council decide if the terms of this Capital Project Ordinance are the same: transfer funds less than \$1,000 without having to do an explicit meeting, adding the things that he had discussed (i.e. the bricks), the playground appears in it as separate item, and the added cushion for a total of \$240,000; this would be the amended Capital Project Ordinance to authorize the expenditure in all phases.
- **Councilwoman Critz** made a **motion** to approve the amended Capital Project Ordinance provided to us by our finance officer/mayor as printed here O-2015-01 and **Councilwoman Cureton** seconded. The motion passed unanimously as follows:

*Ayes: Coffey, Countryman, Critz, Cureton and Neill*

*Nays: None*

- The amended Capital Project Ordinance is as follows:

**ORDINANCE AMENDING THE  
PROJECT ORDINANCE AUTHORIZING DESIGN AND CONSTRUCTION OF A PARK ADJOINING THE TOWN HALL  
O-2015-01**

Pursuant to section 13.2 of Chapter 159 of the General Statutes of North Carolina, the following project ordinance is hereby adopted:

**Section 1:** Capital Project Ordinance O-2014-02 was adopted on April 9, 2015, and is hereby amended.

The project involves the design and construction of a multi-use park consisting of approximately 16,000 square feet on property owned by the Town of Mineral Springs adjacent to the town hall at 3506 South Potter Road. This park is intended to serve the broadest possible cross-section of citizens, with paved walkways, sitting and picnic areas, open lawn areas, and play and activity features.

Stewart Incorporated, located at 200 South College Street, Suite 720, Charlotte, North Carolina has been selected to provide design, permitting, construction bid assistance, and construction management services for this park project.

The Design, Permitting, and Bidding phases have taken place from April 10, 2015 through October 1, 2015, with the Construction phase expected to take place from October 2015 through February 2016.

**Section 2:** It is estimated that the following revenues will be available to complete those projects described in section 3:

General Fund Balance	\$240,000
<b>Total</b>	<b>\$240,000</b>

**Section 3:** The following amounts are appropriated for the projects of the Downtown Park Capital Project fund:

Design and Professional Services (Item #1)	\$27,000
Construction: General Contractor (Item #2)	\$164,800
Construction: Playground (Item #3)	\$40,000
Memorial Bricks (Item #4)	\$2,500
Contingency Allowance (Item #5)	\$5,700
<b>Total</b>	<b>\$240,000</b>

**Section 4:** The Finance Officer is authorized to make periodic payments to Stewart, Incorporated for services provided under "Item #1" based on the work completed in each billing cycle, as specified in the agreement between the town and Stewart

**Section 5:** The Finance Officer is authorized to make periodic payments for work under "Item #2" and "Item #3" to any contractor or contractors approved by the Mineral Springs town council as a result of the Construction Bid process. These payments shall be made only as invoiced in contractor pay requests approved by Stewart in its construction management function. The Finance Officer is authorized to approve change orders of up to One Thousand Dollars (\$1,000.00) for any individual change, and may transfer amounts of up to \$1,000.00 between line items including transfers from the Contingency line item ("Item #5) as required by such change orders. Contracts or change orders above that amount must be approved by the town council.

**Section 6:** The Finance Officer is hereby directed to maintain within the Downtown Park Capital Project Fund sufficient detailed accounting records for the project authorized.

**Section 7:** The Finance Officer is directed to report annually on the financial status of the Downtown Park Capital Project Fund.

**Section 8:** The Finance Officer is authorized to transfer funds as required from the General Fund balance into the Downtown Park Capital Project Fund.

**Section 9:** Copies of this Downtown Park Capital Project Ordinance shall be filed with the Town Clerk and the Finance Officer.

**ADOPTED** this the 15th day of October, 2015.

\_\_\_\_\_  
Frederick Becker III, Mayor

Attest:

\_\_\_\_\_  
Vicky A. Brooks, Clerk



- Mayor Becker referred to Mr. Blackman and commented that they will work closely on getting the i's dotted and the t's crossed, so they can run any final contract by the attorney; if there were significant changes they council would have to reconvene. The playground may have to be approved separately by this board, but we have time to do that in November if Mr. Blackman has his numbers back by then.

**5. Eagle Scout Project – Evan Wunder**

- Mr. Evan Wunder updated the council on his proposed Eagle Scout project. Mr. Wunder contacted the county permitting committee and does not need any building permits for the bird houses or signs. Mayor Becker suggested that Mr. Wunder get confirmation (i.e. email) saying that this project does not require permits to put in his project file to cover himself. Mayor Becker noted that he had received an email from Mr. Blackman (Stewart, Inc.), which he forwarded to Mr. Wunder stating that the bird house project would in no way interfere with the plans that he is going to be working on for analysis and possibly upgrading that trail. Mayor Becker also noted that Ms. Brooks has already said that those types of signs are zoning compliant; they are little informational plaques.
- Councilwoman Coffey stated that she thought Mr. Wunder has done a great job and she is glad that he had to go through the process and meet or talk to the people in the county, so that he will understand the process that we all go through. Councilwoman Coffey congratulated Mr. Wunder on getting his project approved. Councilwoman Critz asked Mr. Wunder what his project's estimated cost was. Mr. Wunder responded that it was currently an estimate of \$600. Mayor Becker asked if Mr. Wunder was going to be doing fundraising and if he would be asking the town for a match depending on how his fundraising goes. Mr. Wunder responded yes. Councilwoman Critz mentioned that the town typically (on our other Boy Scout projects) was funding them at about 50% and allowing the Boy Scout in question to raise the other 50%. Councilwoman Critz asked Mr. Wunder if wanted the 50% to get going. Mayor Becker commented that the council has to approve it and he didn't know where his process stands with the Scout Council. Scout Leader Tim McCulla explained to Mr. Wunder that the council was proposing to put money in his pocket now to seed his funding for his project or if he was planning on self-funding the council would give him a payment on the back end once he had accrued the costs. Mr. McCulla stated that it was an excellent and very generous offer that they appreciated. Mr. Wunder explained that he had one more section of the approval to get. Mayor Becker invited Mr. McCulla to come forward to help Mr. Wunder. Mr. McCulla introduced himself as the Assistant Scout Master of Troop #46 and explained that they are working with Mr. Wunder and Mr. Amadio (next on the agenda). Mr. McCulla stated that it was extraordinary generous offer and it was certainly greatly appreciated. Councilwoman Critz commented that this would allow Mr. Wunder money to get started working while he is in the process of fundraising. Councilman Countryman asked if the council approved his project. Mr. Wunder asked if he should come back at a later date when he has the district's and scouts' approval. Mr. McCulla stated that he did not believe that Mr. Wunder has gone to district yet. Mayor Becker responded that he needs district approval before the town pays him, because the project is "not alive", but the council could authorize a certain payment that would be on record on the minutes and then as

finance officer he could write that check at any time once it has been authorized by the council [scout].

- **Councilwoman Critz** made a **motion** to approve Evan Wunder's project and that we fund him at 50% and that he will supply that information to us once he has it. Attorney Griffin asked Mayor Becker (as the finance officer) if it was a wise motion (open-ended). After a brief discussion, the consensus of the council was that they would fund up to 50% of the project not to exceed \$400, and the amended motion was to approve Evan Wunder's project and that we fund him at 50% with a "not-to-exceed \$400" and that he will supply that information to us once he has it. **Councilman Countryman** seconded the aforementioned amended motion by Councilwoman Critz. The motion passed unanimously as follows:

Ayes: Coffey, Countryman, Critz, Cureton and Neill

Nays: None

#### 6. **Eagle Scout Project – Nickolas Amadio**

- Mineral Springs resident and Troop 46 member Nickolas Amadio explained that his project plan was to create beautification around the flag pole on the right side of the building [town hall] creating a more beautiful area for the public to see to the flag. It would be paved with pavers ("country side" paver), which in the sunlight looks reddish against the building. There will be a knee wall surrounding the paved area as kind of a border and the paved area will be surrounded by knockout roses matching the ones on the side of the building. Mayor Becker mentioned to Mr. Amadio that they had earlier discussed the electrical receptacle, but he didn't see it on the plans. Does this work around the existing electrical receptacle where it's kind of tucked in right at the edge where it is not in the way? It's a good design now that we see what electricians are charging for underground work. Mr. Amadio responded that they are going to be working around the electrical box and will be making it look more appealing, so they can cut down on costs. This won't cost the town anything; it will be raised by Mr. Amadio. Mayor Becker asked Mr. Amadio if he didn't think he would apply for matching funding from the town at this time. Mr. McCulla responded that they would certainly appreciate it. Mayor Becker asked Mr. Amadio if they had heard back from the inspections department about whether his project had any liability for permitting and inspection. Mr. Amadio responded yes, they had been contacted and they have approved the project; there is no permitting needed. They would only need a permit if they had decided to do a sitting area in the project, but there is no sitting area, it is just walking so there are no permits needed. Mayor Becker responded that was good to know, as long as inspections signs off and he keeps a waiver in his project file. Councilwoman Critz explained that the council has dealt with seven scout projects to date, so they have significant history of working with the scouts and she thought they would all agree that they get far more than they give; it's an honor for the town to help with their funding and to encourage them in their projects, because their projects leave permanent things for the community that go beyond today and beyond this generation. It is an exciting thing to be involved in. When the community was polled about the town's outdoor parks and greenways there was an overwhelming positive response to all of it; these are things that the community values. Councilwoman Critz continued that it seems like maybe 50% is generous, but to the town they are getting way more in return and she thanks the scouts. Mr.

Amadio commented that he was glad that he could give back to the community; he loves this little town.

- Mayor Becker mentioned that Mr. Wunder and Mr. Amadio are the first Troop #46 projects; the town has been represented by a lot of troops (7, 442, 18, 53) in nine or ten projects and it is quite an honor.
- Mr. Amadio asked if the council had any further questions about the project. Mayor Becker responded that Mr. Amadio is literally in the development phase and asked the council if they wanted to approve the project at this level. Councilman Countryman commented that he thought it was more of an informational. Mayor Becker replied that Mr. Amadio needed to get scout council stuff before he would need to sign anything. Councilman Countryman responded that Mr. Amadio is going to have to come back and follow-up with the official. Mayor Becker stated that no action is required at this time.

**7. Discussion of Seeking a Replacement Council Member**

- Mayor Becker reminded the council about the “stuff” they reviewed from the Institute of Governments about procedures that are permissible (which is basically almost anything) on replacing a council member. Mayor Becker asked the council what they want to do. Interestingly enough we did have a pleasure of our first applicant for that position, which was nice to have that contribution; it is somebody who has already been vetted since she has shown interest in the past in serving. Councilman Countryman stated that he thought consideration should be given to Anna [Plyler] for that position, but before that would happen this board should have an opportunity to ask her some questions to help them better understand her rationale for seeking the position, because some of the council questions themselves on why they actually occupy the position. Councilman Countryman would like to get a thought of where she sees the vision of this community since the council has that as their best interest; he is certainly open and is encouraged to have Anna consider the job, because there are not a lot of people in this town that want to participate (sadly). Councilman Countryman commented that he didn’t know if it would be appropriate or at what time it might be appropriate that they should be given the opportunity to have that discussion. Councilman Countryman asked the advice of Mayor Becker and Attorney Griffin as to when it was appropriate to conduct that questioning period, because he thought they needed to move forward. Mayor Becker responded that the flexibility is absolute. Attorney Griffin commented that he thought the council was first going to consider the procedures, before they start interviewing, but that was put to the council as there are no fast rules. Either the council decides they are going to do it by motion or they are going to go out and seek individual candidates or they are going to meet collectively to talk about this. The first step is “how you are going to go about seeking a replacement” – decide what the council procedures are. Is there a timeframe for others to apply? Are you going to seek interviews? Are you going to give another 30 days and then discuss those who applied? If some of the council finds somebody out there on their own who has an interest will they come back to discuss it? Attorney Griffin advised the council to decide what their procedure was for how they are going to do this and what the timeframe was for when they are going to make their decision. Councilwoman Coffey asked if it was imminent that they make that decision tonight. Councilman Countryman responded no, it is not.

Councilwoman Coffey stated that she did not feel comfortable with this this evening, she feels comfortable with Ms. Fitch; it has nothing to do with her. Attorney Griffin commented that they may talk with her individually or collectively. Councilwoman Coffey stated that she thought it would be good not to have this discussion tonight. Councilman Countryman responded that it was part of the process, so they need to have this discussion (not about appointing somebody) about how they are going to do it. Councilwoman Coffey offered that the council has a lot on the table right now, such as the bidding process and all of these major projects and decisions going on that they have to consider and she would rather have some time to take a look at this as she does know some other people that may have an interest (planning board members had made mention) and she thought there has to be time given to everybody that might have an interest to present their petition. Councilman Countryman responded that he was not in any way suggesting that they vote on anybody, he was just saying that they need to have a discussion and let other people if they are so inclined to make their presence known, but they have to start somewhere, so tonight they are starting to say “we need to be interested”. Councilwoman Neill stated that we have one applicant now, so do we just go out and talk to people; she has already talked to several people. Councilwoman Coffey commented that the process that she thought Attorney Griffin was alluding to is not about identifying candidates, it about what method is the council going to go about. Councilman Countryman responded that all he was saying is that (from his perspective) the council needs to move forward more quickly than not, because the longer they delay the appointment of someone then that just takes one more member of the community out of the ability to be involved in the city council.

- Mayor Becker commented on the timing – since municipal elections are right around next month, the Institute of Governments and the League have those trainings for new council members, so it would be in any applicants best interest for the council to have settled the matter by the end of the year, so they are in place and can sign up for one of those classes as if they were elected. The target date should be by the end of the year. While people can serve without taking those classes, they are very useful for a new council member. Councilwoman Critz commented that it would be prudent on the council’s part to make sure that whomever they are willing to appoint has the opportunity for the education, because it is extremely valuable and it would be a shame to miss that window of opportunity for that individual, because you are basically asking them to perform a duty that they are not trained or equipped to do. Councilwoman Critz stated that she thought this council demonstrated earlier tonight that they are all prone to want more information as opposed to less; “we always have a history of doing due diligence, maybe to some people to a fault”. Councilwoman Critz mentioned that she thought each of the council has spoken with people in the community and have had people speak to them about the vacancy, but to her knowledge Mrs. Plyler-Fitch is the first one to throw her hat in the ring, so she would like to see the council talk with her. If they don’t want to do it collectively (if that would make her uncomfortable and put her on the spot) then they can meet with her individually over a cup of coffee; that would be prudent for the council to get to know her better and allow her to get to know the council better. The advance the council had when they appointed Councilwoman Coffey was that they had known her through the

planning board, so there was for knowledge. When Councilwoman LaMonica ran for office, she came from the planning board, so they council still had this history.

- Councilman Countryman guessed to Attorney Griffin's point is that they need to come to a conclusion as a council as to a deadline of having somebody in place, for example December 31<sup>st</sup>. The other thing the council needs to consider is how they solicit participation. In the past when they looked for people for the planning board or board of adjustment they sent out a postcard or put a bulletin in the newspaper, but Councilman Countryman was not sure those things were cost effective, because if you want to serve this community it's already in your heart and you have a desire to do that and you don't have to be promoted by a newspaper ad or card that solicits in your mailbox and if you do you are probably not the right person for the job. If you have a neighbor or a friend that you think might be interested, then you need to speak with them and you need to tell them that we are on a deadline and they need to contact this board or our town clerk and say they are interested, because we are going to move forward and as many people as we speak to or become acquainted with and look at their credentials and see what they have on their mind would behoove them. Councilman Countryman stated that he didn't think they needed to run an ad or send out any cards; if we only have one applicant so be it, but the council needs to have it done by the 31<sup>st</sup> of this year. Councilwoman Critz suggested changing that date to their meeting in December (the 10<sup>th</sup>).
- Councilwoman Coffey asked Ms. Brooks about an application. Ms. Brooks responded that they did have a questionnaire. Councilwoman Coffey suggested that there has to be some type of way that they can alert the public – whether you just put something on the website or something; we don't want to look like we have just kind of put something together – “we decided this”. The opportunity hasn't been put out there; everybody may not know that Councilwoman LaMonica resigned. Councilman Countryman commented that it is on the website right now. Ms. Brooks clarified that it wasn't, but the minutes were on there and people would actually have to read the minutes. Councilman Countryman suggested putting a blurb on the website saying there is a vacancy on the city council and if they are interested to contact the town clerk. Councilwoman Critz added “before December 10<sup>th</sup>”. Mayor Becker asked if there were any interim steps that should be considered as applicants come in – do they need to get handed that little questionnaire, do we want to give Mrs. Plyler-Fitch the questionnaire, have we vetted that questionnaire or do we want to rewrite it in time for the next meeting so the council can approve it. Ms. Brooks provided the council with the information on the existing questionnaire: name, address, etc; how many years have you been a Mineral Springs resident; commitment to attending town council meetings is required, do you foresee any reason why you would not be able to attend meetings; if you could change one thing in the Town of Mineral Springs what would it be; what experience/education do you have that would qualify you for this position; and list any government, nonprofit committee, commission on which you have served. Mayor Becker commented that those seem pretty nice and straight forward; he didn't think they have any problem using that for an applicant that comes across the threshold. Councilwoman Critz commented that it would be less intimidating if Ms. Brooks would let the council know who throws their hat in the ring; it will allow them to contact them individually rather than collectively. Ms.

Brooks asked the council if they wanted to put a deadline for the application. After a brief discussion and on the advice of Attorney Griffin for the council not to box themselves in by making a motion but rather to have a consensus of the council on their procedure to replace the council member, there was a consensus of the council that applicants have their questionnaires completed and returned to Ms. Brooks by the close of business on November 12<sup>th</sup> (by 2:00 p.m.); the questionnaires will be presented to the council at the November 12<sup>th</sup> meeting (it will not be on the agenda) and they will have from that date until the December 10<sup>th</sup> meeting to review the questionnaires and contact the applicants; applicants can make their presentation in front of the council on December 10<sup>th</sup>; and the council will do their final interviews, make their decision and appoint the applicant that evening (after the organizational meeting). It was also noted that Ms. Brooks would put something on the website announcing the vacancy

- Councilwoman Critz and Mayor Becker thanked Mrs. Plyler-Fitch for being the first and maybe the only.

#### **8. 2<sup>nd</sup> Annual Festival Wrap-Up and Consideration of the 2016 Festival Date**

- Town Clerk Vicky Brooks presented the final budget to the council. Revenues: sponsors - \$1,877.50; food vendors - \$200.00; craft vendors/exhibitors - \$270.00 totaling \$2,347.50. Expenditures were \$2,858.49; the town actually expended \$685.99 on the entire festival. Ms. Brooks commented that she thought we had a wonderful event and that everybody had a great time. Ms. Brooks stated that she wanted to personally thank Ms. Ridings and Mayor Becker for all the extra work that they had to do on her behalf.
- Ms. Brooks asked the council about next years' festival and setting a date for it. Councilwoman Critz asked if Ms. Brooks had a date in mind. Ms. Brooks responded the week before this one, which would be September 10<sup>th</sup>. Councilwoman Critz asked Ms. Brooks if she could tell the council what last years' numbers were for expenditures and what we brought in (for comparison). Ms. Brooks responded that she could and noted that there were a lot of events going on in Union County and close by in South Carolina that interfered with a lot of stuff that day [this years' festival]. Mayor Becker commented that we found that our first year festival (the Saturday after Labor Day) turned out to be a good time in terms of conflicts and other schedules. Councilwoman Critz publicly thanked Ms. Ridings for such a great job that she did on getting all the gifts (donated products and services); they were really superb and a big hit. Councilwoman Neill also commented that Ms. Ridings did a great job and Councilwoman Cureton thanked Ms. Ridings for all of her hard work. Ms. Brooks reported that last year the town expended \$1,395.41 and noted that we did much better; however, we did not have the band this year and we upped our sponsorships and got more than we thought we would at the \$250 level. Mayor Becker stated that we actually provided more (except for not having the band this year), while costing the taxpayers less. Ms. Brooks mentioned the only thing we might consider is if we want to get more advertising out there it costs a lot of money to do extra advertising other than what we were able to provide this year. Councilwoman Critz stated that she would like to consider more advertising. Mayor Becker commented that could happen as we go along, but he thought the best thing to do is to nail down the date if the council

feels that's a good date, so it can be on Ms. Brooks' calendar and she can start reserving vendors and so forth early on.

- **Councilwoman Coffey** made a **motion** for September 10, 2016 as the date for the festival and **Councilwoman Critz** seconded. The motion passed unanimously as follows:

*Ayes: Coffey, Countryman, Critz, Cureton and Neill*

*Nays: None*

## 9. **Literacy Council Update**

- Mayor Becker stated that he didn't have a real update, except that "they are dropping like flies", our other member Ms. [Amy] Brooks happens to have a very important Nursing School final exam of some sort the morning after the spelling bee night and she really feels that she is going to be studying. Ms. Brooks loves the spelling bee and would love to do it, but she feels compromised with that with that real important exam, which is already on her calendar. Mayor Becker explained that he was thinking they might want to go into plan B on this one, which is to continue to give them the donation and with our regrets; the program can just have the Mineral Stings on hiatus. Mayor Becker thought they would love to work with us; "we are not gone, we are down, but not out". We will be back next year and it will give Mayor Becker some lead time on getting the Parkwood teacher and Ms. Brooks will still be around and maybe with a year lead time, if she's got a shift with her new nursing job she might be able to get that night off. Councilwoman Critz commented in light of their previous discussion on replacing the council member, she was uncomfortable with Mayor Becker being gone that Thursday night as well. Mayor Becker stated that the council has already voted and approved to fund the Literacy Council whether or not the spelling bee team is participating, so we will just give our regrets; he loves it, but there are just too many things that are not falling into place. Councilwoman Critz mentioned that our mayor is an excellent speller. Mayor Becker commented that they do enjoy the spelling bee and the Mineral Stings will fly again. Councilwoman Neill noted that the spelling bee is so much fun; she was so surprised at how much fun it is. Mayor Becker explained that it is an adult spelling bee and you have to be 18, otherwise he had another Mineral Springs resident that would be a candidate. That's the other problem trying to get somebody from the school who is 18 in the fall. It used to be in the spring, so you were getting these people in April that were 18 (seniors at Parkwood), but for the November date we don't get many 18 year olds from the school, which is why we had to go to an alumna; it is still Mineral Springs and still Parkwood, which is really the relationship we are trying to cultivate as we support the Literacy Council.

## 10. **Staff Reports**

- At the reconvened meeting of October 8, 2015 on Thursday, October 15, 2015, Ms. Ridings commented that last week the council thanked her for the door prizes and she appreciated that, but Ms. Brooks also got some of the door prizes. Ms. Ridings mentioned how hard Ms. Brooks actually worked in spite of everything else that was going on and should be commended for doing as much as she did with everything else in her life. Ms. Ridings explained that she just wanted to say that,

because Ms. Brooks needs to be recognized for all her hard work as well. Councilwoman Coffey commented that they are eternally grateful, they know what Ms. Brooks does and are so sorry that they didn't speak on it; sometimes they just don't think. Councilwoman Cureton stated that they appreciate what Ms. Brooks did. Councilwoman Critz offered that she thought most of the council had said things to Ms. Brooks individually, but Ms. Ridings is right about the public acknowledgments. Mayor Becker commented that we had a lot of door prizes through everyone's joint effort and thanked Ms. Brooks and Ms. Ridings for managing to pull that off; he thought there were a lot of satisfied festival attendees who were able to get some good prizes.

11. **Other Business**

- There was none.

12. **Adjournment**

- **Councilwoman Neill** made a **motion** to recess the meeting to Thursday, October 15, 2015 at 7:30 p.m. and **Councilman Countryman** seconded. The motion passed unanimously as follows:

*Ayes: Coffey, Countryman, Critz, Cureton and Neill*

*Nays: None*

- The meeting was recessed at 8:57 p.m.
- At 7:34 p.m. on Thursday, October 15, 2015 the meeting was reconvened.
- **Councilwoman Coffey** made a motion to adjourn the meeting and **Councilwoman Neill** seconded. The motion passed unanimously as follows:

*Ayes: Coffey, Countryman, Critz, Cureton and Neill*

*Nays: None*

- The meeting was adjourned at 7:45 p.m.
- The next regular meeting will be on Thursday, November 12, 2015 at 7:30 p.m. at the Mineral Springs Town Hall.

Respectfully submitted by:

---

Vicky A. Brooks, CMC, NCCMC, Town Clerk

---

Frederick Becker III, Mayor



SEPTEMBER 2015  
TOWN OF MINERAL SPRINGS  
PERCENTAGE REPORT

<b>SEPTEMBER 30, 2015 REGULAR TAX</b>	<b>2015</b>	<b>2014</b>	<b>2013</b>	<b>2012</b>
BEGINNING CHARGE	59109.3	64,380.78	64,929.11	66,123.64
TAX CHARGE				
PUBLIC UTILITIES				
DISCOVERIES	1579.1	2.22	2.44	2.44
NON-DISCOVERIES	7.8			
ABATEMENTS	(31.01)			(2.41)
<b>TOTAL CHARGE</b>	<b>60,665.19</b>	<b>64,383.00</b>	<b>64,931.55</b>	<b>66,123.67</b>
BEGINNING COLLECTIONS	2302.94	63,469.59	64,423.74	65,809.23
COLLECTIONS - TAX	2501.16	22.43	29.92	9.39
COLLECTIONS - INTEREST	0	2.41	6.89	
<b>TOTAL COLLECTIONS</b>	<b>4,804.10</b>	<b>63,492.02</b>	<b>64,453.66</b>	<b>65,818.62</b>
BALANCE OUTSTANDING	55,861.09	890.98	477.89	305.05
<b>PERCENTAGE OF REGULAR</b>	<b>7.92%</b>	<b>98.62%</b>	<b>99.26%</b>	<b>99.54%</b>
<b>COLLECTION FEE 1.5 %</b>	<b>37.52</b>	<b>0.37</b>	<b>0.55</b>	<b>0.14</b>

Mineral Springs Prior Years Property Tax Report  
September 2015

September 31, 2015	2011	2010	2009	2008	2007	2006	2005		
<b>BEGINNING CHARGE</b>	<b>\$64,878.42</b>	<b>\$64,737.60</b>	<b>\$63,911.13</b>	<b>\$65,443.06</b>	<b>\$52,276.82</b>	<b>\$51,397.02</b>	<b>\$49,217.72</b>		
PUBLIC UTILITIES	\$1,319.20	\$1,251.60	\$1,218.28	\$1,112.42	\$1,056.90	\$779.12	\$624.69		
MINIMAL RELEASES	(\$145.21)	(\$152.88)	(\$157.18)	(\$158.76)	(\$150.55)	(\$50.50)	(\$47.49)		
DISCOVERIES	\$61.82	\$321.61	\$46.46	\$46.72	\$117.44	\$417.27	\$199.93		
ABATEMENTS (RELEASES)	(\$296.43)	(\$471.47)	(\$110.61)	(\$1,309.91)	(\$43.76)	(\$10.50)	(\$9.14)		
<b>TOTAL CHARGE</b>	<b>\$65,817.80</b>	<b>\$65,686.46</b>	<b>\$64,908.08</b>	<b>\$65,133.53</b>	<b>\$53,256.85</b>	<b>\$52,532.41</b>	<b>\$49,985.71</b>		
PREVIOUS COLLECTIONS	\$65,595.31	\$65,435.62	\$64,604.02	\$64,899.32	\$53,094.58	\$52,355.90	\$49,890.49		
<b>PREVIOUS BALANCE DUE</b>	<b>\$222.49</b>	<b>\$250.84</b>	<b>\$304.06</b>	<b>\$234.21</b>	<b>\$162.27</b>	<b>\$176.51</b>	<b>\$95.22</b>		<b>\$1,445.60</b>
COLLECTIONS - TAX		\$3.64	\$10.03	\$2.51	\$13.32				\$29.50
COLLECTIONS - INTEREST/FEES		\$1.66	\$44.87	\$44.13	\$3.09				\$93.75
GROSS MONTHLY COLLECTIONS		\$5.30	\$54.90	\$46.64	\$16.41				\$123.25
MISC. ADJUSTMENTS									
<b>TOTAL TAX COLLECTED TO DATE</b>	<b>\$65,595.31</b>	<b>\$65,439.26</b>	<b>\$64,614.05</b>	<b>\$64,901.83</b>	<b>\$53,107.90</b>	<b>\$52,355.90</b>	<b>\$49,890.49</b>		
<b>BALANCE OUTSTANDING</b>	<b>\$222.49</b>	<b>\$247.20</b>	<b>\$294.03</b>	<b>\$231.70</b>	<b>\$148.95</b>	<b>\$176.51</b>	<b>\$95.22</b>		<b>\$1,416.10</b>
<b>PERCENTAGE COLLECTED</b>	<b>99.66%</b>	<b>99.62%</b>	<b>99.55%</b>	<b>99.64%</b>	<b>99.72%</b>	<b>99.66%</b>	<b>99.81%</b>		

# Mineral Springs Unpaid Property Taxes - Real and Personal as of September 30, 2015

Name	Tax Map Number	2011	2010	2009	2008	2007	2006	2005
BOND, CELESTE B	06054063			\$27.92				
BRIDGES JAMES CORBETT	50084062						\$1.84	\$1.91
BROOKS, STEPHEN R	50089854							\$1.13
CAROLINA STREET SUPPLY	50103059		\$6.88					
CAROLINA STREET SUPPLY, SHEPPARD JONATHAN	848391	\$6.88						
CMH CONTRACTING INC	50092570						\$14.85	
COOMBER CUSTOM MASONRY LLC	1812652	\$10.44						
CURVES OF MINERAL SPRINGS	50092178						\$8.54	
CUSTOM DESIGN CONCRETE	50092179			\$12.02	\$10.46	\$9.82	\$8.54	
D'AMICO, JAMES L	06054024	\$27.68	\$27.68	\$27.68				
DUNCAN, ROBERT W	50100863			\$2.63				
ELLIOTT, JAMES EDWARD & MARIO JAMES ELLIOTT	06060006E	\$24.00	\$24.00	\$24.00	\$24.00	\$10.37	\$10.37	\$10.37
EPIC REALTY GROUP INC	50094704			\$10.46	\$9.10	\$8.54	\$7.43	
FATHER & SON PAINTERS	50093623		\$2.41	\$2.09			\$1.53	
FATHER & SON PAINTERS	264482	\$2.41						
FAULKNER, LONNIE	375789	\$8.72						
FAULKNER, LONNIE JR	50093190		\$8.72	\$8.76	\$5.18	\$10.02		\$8.64
FUNDERBURK, MARGARET B & FUNDERBURK, LERO	06039007D	\$8.21	\$8.21			\$5.66	\$1.50	\$1.50
GRADY, DEITRICH	06018045D	\$8.73	\$8.73	\$8.73	\$8.73	\$7.08		\$7.08
GRIFFIN, FAIRLEY J	05033026	\$6.20	\$6.20	\$6.20	\$6.20	\$3.78	\$3.78	\$3.78
HERRON ENTERPRISES INC	50071162				\$8.78			
HOWARD, ULYSESS	05033036	\$9.43	\$9.43	\$9.43	\$9.35	\$7.90	\$7.90	\$7.90
JUS 4 U II	50090771							\$8.54
KIDZ UNITED CLUB	50094388		\$2.41	\$2.09			\$1.49	
KIDZ UNITED CLUB % SHALETHIA MATTHEWS	591578	\$2.41						

Name	Tax Map Number	2011	2010	2009	2008	2007	2006	2005
LEIGH'S BOOKS 'N SUPPLIES	50094248			\$12.02	\$9.10	\$8.54	\$7.43	
MATHENY, VERNA	455325	\$2.22						
MCDOUGALL, SHERRY CARTER	06084001L	\$6.86	\$6.86	\$6.86	\$6.86			
METHENY, VERNA	50094323		\$2.22	\$2.44			\$2.38	
MEXICAN PAINTERS (THE)	50092685							\$7.43
R & D MASONRY INC	50092552						\$8.54	
REALTY INVESTORS INC	50082898						\$1.02	
ROBERTO BONILLA CUSTOM FRAMING	50104497		\$2.75					
SMITH, MARVIN D & SMITH, DORIS B	06054094	\$31.44	\$31.44	\$31.44	\$31.44			
SNYDER, DOROTHY L	06114092	\$20.37	\$20.37	\$20.37	\$20.37	\$20.69	\$20.69	
STRAING, GRACIE M	05033081	\$6.92	\$6.92	\$6.92	\$3.20			
STRAING, GRACIE M	05033080	\$20.46	\$20.46	\$20.46	\$20.54	\$29.20	\$29.20	
WAXHAW ALL TILE	50099231				\$6.88			
WENDY GREENE AND ASSOCIATES	50093112						\$12.13	\$9.59
WENTZ-BROWN, AMANDA E	06039011A		\$32.40	\$32.40	\$32.40			
WILLIAMS, RUTH & HUSBAND J C WILLIAMS	05033179	\$19.11	\$19.11	\$19.11	\$19.11	\$27.35	\$27.35	\$27.35
Total		\$222.49	\$247.20	\$294.03	\$231.70	\$148.95	\$176.51	\$95.22

## **Town of Mineral Springs**

# **FINANCE REPORT SEPTEMBER 2015**

Prepared for:

The Mineral Springs Town Council

By:

Frederick Becker III  
Finance Officer

**November 12, 2015**

This page has been intentionally left blank.

# Cash Flow Report FY2015 YTD

7/1/2015 Through 9/30/2015

11/2/2015

Page 1

Category Description	7/1/2015- 9/30/2015
<b>INCOME</b>	
Gross Receipts Tax	164.71
Interest Income	427.83
Other Inc	
Copy Charges	1.00
Festival 2015	1,222.50
Gross Receipts	177.09
Memorials	
Bricks	2,550.00
TOTAL Memorials	2,550.00
Zoning	2,085.00
TOTAL Other Inc	6,035.59
Prop Tax 2015	
Receipts 2015	
Tax	2,292.18
TOTAL Receipts 2015	2,292.18
TOTAL Prop Tax 2015	2,292.18
Prop Tax Prior Years	
Prop Tax 2004	
Receipts 2004	
Int	19.85
Tax	13.58
TOTAL Receipts 2004	33.43
TOTAL Prop Tax 2004	33.43
Prop Tax 2005	
Receipts 2005	
Int	37.36
Tax	26.90
TOTAL Receipts 2005	64.26
TOTAL Prop Tax 2005	64.26
Prop Tax 2006	
Receipts 2006	
Int	35.59
Tax	26.77
TOTAL Receipts 2006	62.36
TOTAL Prop Tax 2006	62.36
Prop Tax 2007	
Receipts 2007	
Int	32.27
Tax	26.90
TOTAL Receipts 2007	59.17
TOTAL Prop Tax 2007	59.17
Prop Tax 2008	
Receipts 2008	
Int	60.90
Tax	19.59
TOTAL Receipts 2008	80.49
TOTAL Prop Tax 2008	80.49
Prop Tax 2009	

# Cash Flow Report FY2015 YTD

7/1/2015 Through 9/30/2015

11/2/2015

Page 2

Category Description	7/1/2015- 9/30/2015
Receipts 2009	
Int	56.50
Tax	27.11
TOTAL Receipts 2009	83.61
TOTAL Prop Tax 2009	83.61
Prop Tax 2010	
Receipts 2010	
Int	26.41
Tax	32.50
TOTAL Receipts 2010	58.91
TOTAL Prop Tax 2010	58.91
Prop Tax 2011	
Receipts 2011	
Int	23.73
Tax	28.85
TOTAL Receipts 2011	52.58
TOTAL Prop Tax 2011	52.58
Prop Tax 2012	
Receipts 2012	
Int	17.19
Tax	99.15
TOTAL Receipts 2012	116.34
TOTAL Prop Tax 2012	116.34
Prop Tax 2013	
Receipts 2013	
Int	12.55
Tax	110.53
TOTAL Receipts 2013	123.08
TOTAL Prop Tax 2013	123.08
Prop Tax 2014	
Receipts 2014	
Int	12.32
Tax	230.51
TOTAL Receipts 2014	242.83
TOTAL Prop Tax 2014	242.83
TOTAL Prop Tax Prior Years	977.06
Sales Tax	
Sales & Use Dist	1,649.94
TOTAL Sales Tax	1,649.94
Veh Tax	
Coll	-0.14
2008	-0.04
TOTAL Coll	-0.18
Int 2007	0.21
Int 2008	0.76
Int 2011	0.47
Int 2012	0.76
Int 2013	0.21
Int 2015	6.51
Tax 2007	0.29



# Cash Flow Report FY2015 YTD

7/1/2015 Through 9/30/2015

11/2/2015

Page 3

Category Description	7/1/2015- 9/30/2015
Tax 2008	2.47
Tax 2011	1.43
Tax 2012	4.13
Tax 2013	1.13
Tax 2015	1,113.48
TOTAL Veh Tax	1,131.67
<b>TOTAL INCOME</b>	<b>12,678.98</b>
<b>EXPENSES</b>	
Ads	99.50
Attorney	900.00
Community	
Donation	2,000.00
Greenway	58.38
Maint	600.00
Special Events	28.65
Festival	3,192.26
TOTAL Special Events	3,220.91
TOTAL Community	5,879.29
Dues	4,786.00
Emp	
Benefits	
Dental	222.00
Life	152.04
NCLGERS	2,631.60
Vision	42.00
TOTAL Benefits	3,047.64
Bond	550.00
FICA	
Med	402.87
Soc Sec	1,722.58
TOTAL FICA	2,125.45
Payroll	353.99
Work Comp	1,721.11
TOTAL Emp	7,798.19
Ins	3,542.25
Newsletter	
Post	624.00
Printing	875.29
TOTAL Newsletter	1,499.29
Office	
Clerk	8,301.00
Council	1,800.00
Deputy Clerk	2,577.17
Equip	492.18
Finance Officer	
Park Maint	768.00
Regular	6,900.00
TOTAL Finance Officer	7,668.00
Maint	

# Cash Flow Report FY2015 YTD

7/1/2015 Through 9/30/2015

11/2/2015

Page 4

Category Description	7/1/2015- 9/30/2015
Materials	252.12
Service	1,820.00
<b>TOTAL Maint</b>	<b>2,072.12</b>
Mayor	1,200.00
Misc	65.72
Post	232.72
Supplies	724.78
Tel	2,830.10
Util	457.79
<b>TOTAL Office</b>	<b>28,421.58</b>
Planning	
Administration	
Contract	1,072.60
Salaries	7,176.00
<b>TOTAL Administration</b>	<b>8,248.60</b>
Misc	427.00
<b>TOTAL Planning</b>	<b>8,675.60</b>
Street Lighting	284.96
Tax Coll	
Contract	70.76
Sal	450.00
<b>TOTAL Tax Coll</b>	<b>520.76</b>
Travel	103.17
<b>TOTAL EXPENSES</b>	<b>62,510.59</b>
<b>TRANSFERS</b>	
FROM MM Sav ParkSterling	10,000.00
TO Check Min Spgs	-10,000.00
TO Downtown Park Capital Project Fund	-11,307.14
<b>TOTAL TRANSFERS</b>	<b>-11,307.14</b>
<b>OVERALL TOTAL</b>	<b>-61,138.75</b>

# Account Balances History Report

(Includes unrealized gains)

As of 9/30/2015

11/2/2015

Page 1

Account	6/29/2015 Balance	6/30/2015 Balance	7/31/2015 Balance	8/31/2015 Balance	9/30/2015 Balance
<b>ASSETS</b>					
<b>Cash and Bank Accounts</b>					
Check Min Spgs	31,588.10	33,309.65	13,783.91	1,232.38	44,667.57
Copper Run Escrow	66,841.58	66,847.08	66,852.76	66,858.43	66,863.93
MM Sav Min Spgs	10,581.12	10,581.99	10,582.89	10,583.79	10,584.66
MM Sav ParkSterling	653,901.13	654,035.51	644,174.26	644,311.05	644,443.45
NCCMT_Cash	2,237.06	2,237.14	2,237.25	2,237.39	2,237.51
<b>TOTAL Cash and Bank Accounts</b>	<b>765,148.99</b>	<b>767,011.37</b>	<b>737,631.07</b>	<b>725,223.04</b>	<b>768,797.12</b>
<b>Other Assets</b>					
State Revenues Receivable	0.00	63,920.51	61,303.45	59,725.90	0.00
<b>TOTAL Other Assets</b>	<b>0.00</b>	<b>63,920.51</b>	<b>61,303.45</b>	<b>59,725.90</b>	<b>0.00</b>
<b>TOTAL ASSETS</b>	<b>765,148.99</b>	<b>830,931.88</b>	<b>798,934.52</b>	<b>784,948.94</b>	<b>768,797.12</b>
<b>LIABILITIES</b>					
<b>Other Liabilities</b>					
Accounts Payable	692.76	1,688.77	692.76	692.76	692.76
Escrows	66,662.00	66,662.00	66,662.00	66,662.00	66,662.00
<b>TOTAL Other Liabilities</b>	<b>67,354.76</b>	<b>68,350.77</b>	<b>67,354.76</b>	<b>67,354.76</b>	<b>67,354.76</b>
<b>TOTAL LIABILITIES</b>	<b>67,354.76</b>	<b>68,350.77</b>	<b>67,354.76</b>	<b>67,354.76</b>	<b>67,354.76</b>
<b>OVERALL TOTAL</b>	<b>697,794.23</b>	<b>762,581.11</b>	<b>731,579.76</b>	<b>717,594.18</b>	<b>701,442.36</b>

Mineral Springs Budget Comparison 2015-2016

TOWN OF MINERAL SPRINGS									
BUDGET COMPARISON 2015-2016									
Appropriation dept	Budget	Unspent	Spent YTD	% of Budget	July	August	September	October	November
Advertising	\$ 1,800.00	\$ 1,700.50	\$ 99.50	5.5%	\$ -	\$ -	\$ 99.50		
Attorney	\$ 9,600.00	\$ 8,700.00	\$ 900.00	9.4%	\$ 300.00	\$ 300.00	\$ 300.00		
Audit	\$ 5,100.00	\$ 5,100.00	\$ -	0.0%	\$ -	\$ -	\$ -		
Community Projects	\$ 28,100.00	\$ 22,220.71	\$ 5,879.29	20.9%	\$ 47.58	\$ 39.45	\$ 5,792.26		
Contingency	\$ 3,000.00	\$ 3,000.00	\$ -	0.0%	\$ -	\$ -	\$ -		
Dues	\$ 6,600.00	\$ 1,814.00	\$ 4,786.00	72.5%	\$ 4,719.00	\$ 67.00	\$ -		
Elections	\$ 2,525.00	\$ 2,525.00	\$ -	0.0%	\$ -	\$ -	\$ -		
Employee Overhead	\$ 26,500.00	\$ 18,701.81	\$ 7,798.19	29.4%	\$ 3,968.92	\$ 1,979.44	\$ 1,849.83		
Fire Department	\$ 12,000.00	\$ 12,000.00	\$ -	0.0%	\$ -	\$ -	\$ -		
Insurance	\$ 4,500.00	\$ 957.75	\$ 3,542.25	78.7%	\$ 3,542.25	\$ -	\$ -		
Newsletter	\$ 3,000.00	\$ 1,500.71	\$ 1,499.29	50.0%	\$ 507.63	\$ -	\$ 991.66		
Office	\$ 118,976.00	\$ 90,554.42	\$ 28,421.58	23.9%	\$ 10,257.52	\$ 8,988.27	\$ 9,175.79		
Planning & Zoning	\$ 43,704.00	\$ 35,028.40	\$ 8,675.60	19.9%	\$ 3,891.60	\$ 2,392.00	\$ 2,392.00		
Street Lighting	\$ 2,000.00	\$ 1,715.04	\$ 284.96	14.2%	\$ -	\$ 142.48	\$ 142.48		
Tax Collection	\$ 3,250.00	\$ 2,729.24	\$ 520.76	16.0%	\$ 150.00	\$ 169.69	\$ 201.07		
Training	\$ 3,000.00	\$ 3,000.00	\$ -	0.0%	\$ -	\$ -	\$ -		
Travel	\$ 3,600.00	\$ 3,496.83	\$ 103.17	2.9%	\$ -	\$ -	\$ 103.17		
Capital Outlay	\$ 43,695.00	\$ 43,695.00	\$ -	0.0%	\$ -	\$ -	\$ -		
<b>Totals</b>	<b>\$ 320,950.00</b>	<b>\$ 258,439.41</b>	<b>\$ 62,510.59</b>	<b>19.5%</b>	<b>\$ 27,384.50</b>	<b>\$ 14,078.33</b>	<b>\$ 21,047.76</b>	<b>\$ -</b>	<b>\$ -</b>
<b>Off Budget:</b>									
Tax Refunds					\$ -	\$ -	\$ -		
Interfund Transfers					\$ 5,000.00	\$ 3,315.80	\$ 2,991.34		
<b>Total Off Budget:</b>			<b>\$ 11,307.14</b>		<b>\$ 5,000.00</b>	<b>\$ 3,315.80</b>	<b>\$ 2,991.34</b>	<b>\$ -</b>	<b>\$ -</b>

Mineral Springs Monthly Revenue Summary 2015-2016

TOWN OF MINERAL SPRINGS									
REVENUE SUMMARY 2015-2016									
Source	Budget	Receivable	Rec'd YTD	% of Budget	July	August	September	October	November
Property Tax - prior	\$ 2,400.00	\$ 1,422.94	\$ 977.06	40.7%	\$ 336.71	\$ 322.95	\$ 317.40		
Property Tax - 2015	\$ 59,120.00	\$ 56,827.82	\$ 2,292.18	3.9%	\$ -	\$ 32.98	\$ 2,259.20		
Dupl. Property Tax	\$ -	\$ -	\$ -		\$ -	\$ -	\$ -		
Fund Balance Approp.	\$ -	\$ -	\$ -		\$ -	\$ -	\$ -		
Gross Receipts Tax	\$ 720.00	\$ 378.20	\$ 341.80		\$ -	\$ 164.71	\$ 177.09		
Interest	\$ 1,200.00	\$ 772.17	\$ 427.83	35.7%	\$ 145.44	\$ 143.50	\$ 138.89		
Sales Tax - Electric	\$ 200,000.00	\$ 200,000.00	\$ -	0.0%	\$ -	\$ -	\$ -		
Sales Tax - Sales & Use	\$ 20,560.00	\$ 18,910.06	\$ 1,649.94	8.0%	\$ -	\$ -	\$ 1,649.94		
Sales Tax - Other Util.	\$ 27,300.00	\$ 27,300.00	\$ -	0.0%	\$ -	\$ -	\$ -		
Vehicle Taxes	\$ 4,850.00	\$ 3,718.33	\$ 1,131.67	23.3%	\$ -	\$ 574.41	\$ 557.26		
Zoning Fees	\$ 4,000.00	\$ 1,915.00	\$ 2,085.00	52.1%	\$ 525.00	\$ 735.00	\$ 825.00		
Other	\$ 800.00	\$ (2,973.50)	\$ 3,773.50	471.7%	\$ 376.00	\$ 1,435.00	\$ 1,962.50		
<b>Totals</b>	<b>\$ 320,950.00</b>	<b>\$ 308,271.02</b>	<b>\$ 12,678.98</b>	<b>4.0%</b>	<b>\$ 1,383.15</b>	<b>\$ 3,408.55</b>	<b>\$ 7,887.28</b>	<b>\$ -</b>	<b>\$ -</b>
	<b>December</b>	<b>January</b>	<b>February</b>	<b>March</b>	<b>April</b>	<b>May</b>	<b>June</b>	<b>June a/r</b>	
Property Tax - prior									
Property Tax - 2014									
Dupl. Property Tax									
Fund Balance Approp.									
Gross Receipts Tax									
Interest									
Sales Tax - Electric									
Sales Tax - Sales & Use									
Sales Tax - Other Util.									
Vehicle Taxes									
Zoning Fees									
Other									
<b>Totals</b>	<b>\$ -</b>	<b>\$ -</b>	<b>\$ -</b>	<b>\$ -</b>	<b>\$ -</b>	<b>\$ -</b>	<b>\$ -</b>	<b>\$ -</b>	<b>\$ -</b>

# September 2015 Cash Flow Report

9/1/2015 Through 9/30/2015

11/2/2015

Page 1

Category Description	9/1/2015- 9/30/2015
<b>INCOME</b>	
Interest Income	138.89
Other Inc	
Festival 2015	662.50
Gross Receipts	177.09
Memorials	
Bricks	1,300.00
TOTAL Memorials	1,300.00
Zoning	825.00
TOTAL Other Inc	2,964.59
Prop Tax 2015	
Receipts 2015	
Tax	2,259.20
TOTAL Receipts 2015	2,259.20
TOTAL Prop Tax 2015	2,259.20
Prop Tax Prior Years	
Prop Tax 2007	
Receipts 2007	
Int	3.09
Tax	13.32
TOTAL Receipts 2007	16.41
TOTAL Prop Tax 2007	16.41
Prop Tax 2008	
Receipts 2008	
Int	44.13
Tax	2.51
TOTAL Receipts 2008	46.64
TOTAL Prop Tax 2008	46.64
Prop Tax 2009	
Receipts 2009	
Int	44.87
Tax	10.03
TOTAL Receipts 2009	54.90
TOTAL Prop Tax 2009	54.90
Prop Tax 2010	
Receipts 2010	
Int	1.66
Tax	3.64
TOTAL Receipts 2010	5.30
TOTAL Prop Tax 2010	5.30
Prop Tax 2012	
Receipts 2012	
Int	5.71
Tax	45.49
TOTAL Receipts 2012	51.20
TOTAL Prop Tax 2012	51.20
Prop Tax 2013	
Receipts 2013	
Int	5.94

# September 2015 Cash Flow Report

9/1/2015 Through 9/30/2015

11/2/2015

Page 2

Category Description	9/1/2015- 9/30/2015
Tax	40.47
<b>TOTAL Receipts 2013</b>	<b>46.41</b>
TOTAL Prop Tax 2013	46.41
Prop Tax 2014	
Receipts 2014	
Int	6.89
Tax	89.65
<b>TOTAL Receipts 2014</b>	<b>96.54</b>
<b>TOTAL Prop Tax 2014</b>	<b>96.54</b>
<b>TOTAL Prop Tax Prior Years</b>	<b>317.40</b>
Sales Tax	
Sales & Use Dist	1,649.94
<b>TOTAL Sales Tax</b>	<b>1,649.94</b>
Veh Tax	
Coll	-0.14
Int 2007	0.21
Int 2011	0.47
Int 2012	0.76
Int 2013	0.21
Int 2015	3.30
Tax 2007	0.29
Tax 2008	0.52
Tax 2011	1.43
Tax 2012	4.13
Tax 2013	1.13
Tax 2015	544.95
<b>TOTAL Veh Tax</b>	<b>557.26</b>
<b>TOTAL INCOME</b>	<b>7,887.28</b>
<b>EXPENSES</b>	
Ads	99.50
Attorney	300.00
Community	
Donation	2,000.00
Maint	600.00
Special Events	
Festival	3,192.26
<b>TOTAL Special Events</b>	<b>3,192.26</b>
<b>TOTAL Community</b>	<b>5,792.26</b>
Emp	
Benefits	
Dental	74.00
Life	50.68
NCLGERS	877.20
Vision	14.00
<b>TOTAL Benefits</b>	<b>1,015.88</b>
FICA	
Med	136.21
Soc Sec	582.41
<b>TOTAL FICA</b>	<b>718.62</b>

# September 2015 Cash Flow Report

9/1/2015 Through 9/30/2015

11/2/2015

Page 3

Category Description	9/1/2015- 9/30/2015
Payroll	115.33
<b>TOTAL Emp</b>	<b>1,849.83</b>
Newsletter	
Post	311.40
Printing	680.26
<b>TOTAL Newsletter</b>	<b>991.66</b>
Office	
Clerk	2,767.00
Council	600.00
Deputy Clerk	991.54
Equip	286.96
Finance Officer	
Park Maint	256.00
Regular	2,300.00
<b>TOTAL Finance Officer</b>	<b>2,556.00</b>
Maint	
Materials	64.73
Service	495.00
<b>TOTAL Maint</b>	<b>559.73</b>
Mayor	400.00
Misc	65.72
Supplies	372.15
Tel	361.90
Util	214.79
<b>TOTAL Office</b>	<b>9,175.79</b>
Planning	
Administration	
Salaries	2,392.00
<b>TOTAL Administration</b>	<b>2,392.00</b>
<b>TOTAL Planning</b>	<b>2,392.00</b>
Street Lighting	142.48
Tax Coll	
Contract	51.07
Sal	150.00
<b>TOTAL Tax Coll</b>	<b>201.07</b>
Travel	103.17
<b>TOTAL EXPENSES</b>	<b>21,047.76</b>
<b>TRANSFERS</b>	
TO Downtown Park Capital Project Fund	-2,991.34
<b>TOTAL TRANSFERS</b>	<b>-2,991.34</b>
<b>OVERALL TOTAL</b>	<b>-16,151.82</b>



# Register Report

9/1/2015 Through 9/30/2015

11/2/2015

Page 1

Date	Num	Description	Memo	Category	Amount
9/2/2015	EFT	Debit Card (OOShirts)	Volunteer T-shirts (F...	Community:Special Events:Festival	-216.48
9/3/2015	DE...	Deposit	#507	Prop Tax Prior Years:Prop Tax 2007:Recei...	3.09
			#507	Prop Tax Prior Years:Prop Tax 2007:Recei...	12.89
9/3/2015	DE...	Deposit		Other Inc:Festival 2015	220.00
				Other Inc:Memorials:Bricks	100.00
				Other Inc:Zoning	150.00
9/4/2015	EFT	Debit Card (OOShirts)	Coordinator T-shirt (F...	Community:Special Events:Festival	-34.83
9/9/2015	EFT	Debit Card (B&H Pho...	Audio accessories (F...	Office:Equip	-191.95
9/10/2015	EFT	Debit Card (Farley's)	Food for volunteers &...	Newsletter:Printing	-37.33
9/10/2015	EFT	Debit Card (Tractor S...	Stakes for signs (FY2...	Community:Special Events:Festival	-81.79
9/11/2015	4590	US Postal Service{Po...	Std Mail 1038 pc @\$...	Newsletter:Post	-311.40
9/11/2015	DE...	Deposit	#508	Prop Tax Prior Years:Prop Tax 2009:Recei...	43.51
			#508	Prop Tax Prior Years:Prop Tax 2009:Recei...	6.86
			#508	Prop Tax Prior Years:Prop Tax 2008:Recei...	21.61
			#508	Prop Tax Prior Years:Prop Tax 2008:Recei...	2.51
9/11/2015	DE...	Deposit		Other Inc:Festival 2015	190.00
				Other Inc:Memorials:Bricks	100.00
				Other Inc:Zoning	400.00
9/11/2015	EFT	Debit Card (AOL)	AOL Troubleshooting...	Office:Tel	-4.99
9/12/2015	EFT...	Debit Card (Lowe's)	Speaker wire, plugs	Office:Supplies	-56.82
			Cinder blocks	Office:Maint:Materials	-12.51
9/14/2015	EFT	Debit Card (CrystalPl...	Melody LaMonica aw...	Office:Misc	-65.72
9/14/2015	EFT...	Union County	8/15	Prop Tax 2015:Receipts 2015:Tax	2,259.20
			8/15	Prop Tax Prior Years:Prop Tax 2014:Recei...	6.89
			8/15	Prop Tax Prior Years:Prop Tax 2014:Recei...	89.65
			8/15	Prop Tax Prior Years:Prop Tax 2013:Recei...	5.94
			8/15	Prop Tax Prior Years:Prop Tax 2013:Recei...	40.47
			8/15	Prop Tax Prior Years:Prop Tax 2012:Recei...	5.71
			8/15	Prop Tax Prior Years:Prop Tax 2012:Recei...	45.49
			8/15	Veh Tax:Tax 2013	1.13
			8/15	Veh Tax:Int 2013	0.21
			8/15	Veh Tax:Tax 2012	4.13
			8/15	Veh Tax:Int 2012	0.76
			8/15	Veh Tax:Tax 2011	1.43
			8/15	Veh Tax:Int 2011	0.47
			8/15	Veh Tax:Tax 2008	0.52
			8/15	Veh Tax:Tax 2007	0.29
			8/15	Veh Tax:Int 2007	0.21
			8/15	Veh Tax:Coll	-0.14
			8/15	Other Inc:Gross Receipts	177.09
			8/15	Tax Coll:Contract	-36.81
9/14/2015	EFT	Debit Card (OOShirts)	Coordinator T-shirt R...	Community:Special Events:Festival	34.83
9/15/2015	EFT	NC Department of Re...	6/15/15 Distributions ...	[State Revenues Receivable]	59,725.90
9/15/2015	EFT	NC Department of Re...	7/15 (FY2015)	Sales Tax:Sales & Use Dist	1,649.94
9/15/2015	EFT	Debit Card (Lowe's)	Construction Fencing...	Office:Maint:Materials	-52.22
9/15/2015	EFT	Debit Card (OfficeMax)	Cash Box, Apron (FY...	Office:Supplies	-33.91
9/15/2015	EFT...	Debit Card (WalMart)	Canopy	Office:Equip	-95.01
			Recreational Supplie...	Office:Supplies	-68.45
9/18/2015	EFT	Debit Card (Union Co...	Fire Inspections (FY2...	Community:Special Events:Festival	-160.00
9/19/2015	4591	David M. Ludlow	Deputy service - Festi...	Community:Special Events:Festival	-175.00

# Register Report

9/1/2015 Through 9/30/2015

11/2/2015

Page 2

Date	Num	Description	Memo	Category	Amount
9/19/2015	4592	Kyle D. Hill	Deputy service - Festi...	Community:Special Events:Festival	-175.00
9/21/2015	4593	Duke Power	2035221941 (FY2015)	Street Lighting	-142.48
9/21/2015	4594	Duke Power	1803784140 (FY2015)	Office:Util	-170.57
9/21/2015	4595	Donald Gaddy	Banner Frame Materi...	Community:Special Events:Festival	-95.73
9/21/2015	4596	Neopost Inc	I/N 53224045 Meter ...	Office:Supplies	-72.86
9/21/2015	459...	Municipal Insurance ...		Emp:Benefits:Life	-50.68
				Emp:Benefits:Dental	-74.00
				Emp:Benefits:Vision	-14.00
9/21/2015	4598	Jan-Pro Cleaning Sys...	I/N 35392 Janitorial 9...	Office:Maint:Service	-195.00
9/21/2015	4599	The Enquirer-Journal...	30065439 (FY2015)	Ads	-99.50
9/21/2015	4600	Taylor & Sons Mowin...	I/N 1839 9/15 (FY2015)	Office:Maint:Service	-300.00
9/21/2015	460...	Xerox Corporation		Office:Supplies	-64.99
				Newsletter:Printing	-642.93
9/21/2015	4602	Windstream	061345970 (FY2015)	Office:Tel	-66.82
9/21/2015	4603	Monroe Broadcasting	I/N 39918 Festival Sp...	Community:Special Events:Festival	-175.00
9/21/2015	4604	Union County Public ...	84361*00 (FY2015)	Office:Util	-21.42
9/21/2015	4605	Bouncing Your Way	Cust #280 9/19/15 (F...	Community:Special Events:Festival	-656.51
9/21/2015	4606	Sign Pro	I/N 11308 Banner Ch...	Community:Special Events:Festival	-950.00
9/21/2015	4607	Ken Newell	Welcome Signs 7/15 ...	Community:Maint	-600.00
9/21/2015	4608	WUES PTO	2015 Sponsorship (F...	Community:Donation	-2,000.00
9/21/2015	4609	**VOID**Clark, Griffin...	misprint (FY2015)	Attorney	0.00
9/21/2015	4610	**VOID**Windstream	misprint (FY2015)	Office:Tel	0.00
9/21/2015	4611	Clark, Griffin & McCol...	I/N 5075 9/15 (FY2015)	Attorney	-300.00
9/21/2015	4612	Windstream	061348611 (FY2015)	Office:Tel	-290.09
9/21/2015	4613	Holloway Music	Speaker Rental (FY2...	Community:Special Events:Festival	-106.75
9/21/2015	EFT...	Union County {NCVTS}	NCVTS 1508	Veh Tax:Tax 2015	544.95
			NCVTS 1508	Veh Tax:Int 2015	3.30
			NCVTS refunds 1507	Veh Tax:Tax 2015	0.00
			NCVTS 1508	Tax Coll:Contract	-14.26
9/22/2015	DE...	Deposit	#509	Prop Tax Prior Years:Prop Tax 2010:Recei...	1.66
			#509	Prop Tax Prior Years:Prop Tax 2010:Recei...	3.64
			#508	Prop Tax Prior Years:Prop Tax 2009:Recei...	1.36
			#509	Prop Tax Prior Years:Prop Tax 2009:Recei...	3.17
			#509	Prop Tax Prior Years:Prop Tax 2008:Recei...	22.52
			#509	Prop Tax Prior Years:Prop Tax 2007:Recei...	0.43
9/22/2015	DE...	Deposit		Other Inc:Festival 2015	252.50
				Other Inc:Memorials:Bricks	950.00
				Other Inc:Zoning	250.00
9/29/2015	EFT...	Paychex	Salary 9/15	Office:Clerk	-2,600.98
			Supplement 9/15	Office:Clerk	0.00
			Hours 9/15	Office:Deputy Clerk	-991.54
			Salary 9/15	Office:Finance Officer:Regular	-2,162.00
			Salary 9/15	Office:Finance Officer:Park Maint	-240.64
			Salary 9/15	Office:Mayor	-400.00
			Salary 9/15	Office:Council	-600.00
			Salary 9/15	Planning:Administration:Salaries	-2,248.48
			Salary 9/15	Tax Coll:Sal	-150.00
				Emp:FICA:Soc Sec	-582.41
				Emp:FICA:Med	-136.21
9/29/2015	EFT...	NC State Treasurer	9/15 LGERS contribu...	Office:Clerk	-166.02
			9/15 LGERS contribu...	Office:Finance Officer:Regular	-138.00

# Register Report

9/1/2015 Through 9/30/2015

11/2/2015

Page 3

Date	Num	Description	Memo	Category	Amount
			9/15 LGERS contribu...	Office:Finance Officer:Park Maint	-15.36
			9/15 LGERS contribu...	Planning:Administration:Salaries	-143.52
			9/15 employer contrib...	Emp:Benefits:NCLGERS	-877.20
9/29/2015	4614	Janet Ridings	Mileage & Meal - Deb...	Travel	-103.17
9/29/2015	4615	Duke Power	1819573779 (FY2015)	Office:Util	-22.80
9/29/2015	4616	Forms & Supply, Inc.	I/N 3411478-0 & -1 in...	Office:Supplies	-75.12
9/29/2015	4617	R.C.S., Inc.	I/N 82752 Portable R...	Community:Special Events:Festival	-400.00
9/29/2015	4618	Stewart Incorporated	I/N 49107 8/31/15 (F...	[Downtown Park Capital Project Fund]	-2,991.34
9/30/2015	EFT	Paychex Fees	9/15 (FY2015)	Emp:Payroll	-115.33
9/30/2015	DE...	Deposit		Other Inc:Memorials:Bricks	150.00
				Other Inc:Zoning	25.00
<b>TOTAL 9/1/2015 - 9/30/2015</b>					<b>43,435.19</b>
<b>TOTAL INFLOWS</b>					<b>67,509.26</b>
<b>TOTAL OUTFLOWS</b>					<b>-24,074.07</b>
<b>NET TOTAL</b>					<b>43,435.19</b>

This page has been intentionally left blank.

September 2015

Revenue Details

This page has been intentionally left blank.

DATE 8/31/15  
 TIME 14:02:15  
 USER PHH

PAGE 29  
 PROG# CL2138

UNION COUNTY  
 COLLECTIONS BY RGCD/REV UNIT/YR-DATE RANGE  
 DEPOSIT DATE RANGE: 8/01/2015 THRU 8/31/2015  
 REPORT GROUP: 100 REAL AND PERSONAL  
 REVENUE UNIT: 990 TOWN OF MINERAL SPRINGS

YEAR	TAXES, ASSESSMENTS & MISC. CHARGES	LATE LIST	INTEREST	TOTAL COLLECTED	COMMISSION	NET OF COMMISSION
2012	45.49		5.71	51.20	.77	50.43
2013	40.47		5.94	46.41	.70	45.71
2014	89.56	.09	6.89	96.54	1.45	95.09
2015	2,256.43	2.77		2,259.20	33.89	2,225.31
TOTAL	2,431.95	2.86	18.54	2,453.35	36.81	2,416.54

(DK)

DATE 8/31/15  
 TIME 14:02:15  
 USER PHH

PAGE 49  
 PROG# CL2138

UNION COUNTY  
 COLLECTIONS BY RGCD/REV UNIT/YR-DATE RANGE  
 DEPOSIT DATE RANGE: 8/01/2015 THRU 8/31/2015  
 REPORT GROUP: 200 REGISTERED VEHICLE  
 REVENUE UNIT: 990 TOWN OF MINERAL SPRINGS

YEAR	TAXES, ASSESSMENTS & MISC. CHARGES	LATE LIST	INTEREST	TOTAL COLLECTED	COMMISSION	NET OF COMMISSION
2007	.29		.21	.50	.01	.49
2008	.52			.52	.01	.51
2011	1.43		.47	1.90	.03	1.87
2012	4.13		.76	4.89	.07	4.82
2013	1.13		.21	1.34	.02	1.32
TOTAL	7.50		1.65	9.15	.14	9.01

(DAC)



Invoice Date	Invoice Number	Description	Invoice Amount
08/31/2015	200.1-15/08	Tax/Fee/Int - AUG15	\$9.01
08/31/2015	1602VEHGR	AUG GROSS VEH RENTAL RECEIPTS	\$177.09
08/31/2015	100.1-15/08	Tax/Fee/Int - AUG15	\$2,416.54

Vendor No.	Vendor Name	Check No.	Check Date	Check Amount
10870	TOWN OF MINERAL SPRINGS	00041899	09/14/2015	2,602.64



**County of Union**

500 North Main Street  
 Monroe, North Carolina 28112

Vendor Number    Check Date    Check Number  
 10870            09/14/2015    00041899

"This disbursement has been approved as required by the Local Government Budget and Fiscal Control Act."

**\$2,602.64**

Pay Two Thousand Six Hundred Two Dollars and 64 cents \*\*\*\*\*

To The            TOWN OF MINERAL SPRINGS  
 Order Of        PO BOX 600  
                     MINERAL SPRINGS NC 28108

**EFT COPY  
 NON-NEGOTIABLE**

AP



**County of Union**

500 North Main Street  
 Monroe, North Carolina 28112

10870  
 00041899

**ADDRESS SERVICE REQUESTED**

TOWN OF MINERAL SPRINGS  
 PO BOX 600  
 MINERAL SPRINGS NC 28108

Batch 3295

NCVTS A/P Receipt Distribution  
For the month ending: 08/31/2015

NCVTS A/P Receipt Distribution  
For the month ending: 08/31/2015

NCVTS A/P Receipt Distribution  
For the month ending: 08/31/2015

R/G M/I	Entity	VndNo-R	Inv No	Tax&Fee	IntOnly	Cmn	Net	Sts
				Amt	Amt	Cst	Amt	
400 001	Union County	0-0		638,600.59	4,650.56	15,376.20	627,874.95	No Chk
400 011	Countywide Fire Tax	0-0		10,473.24	37.78	245.89	10,265.13	No Chk
400 012	Countywide EMS Tax	0-0		1,910.87	6.90	44.81	1,872.96	No Chk
400 015	Springs Fire Tax	638-	VTFN1508-1	5,055.94	31.98	124.57	4,963.35	No Chk
400 020	Stallings Fire Tax	440-	VTFN1508-1	8,419.60	59.22	203.71	8,275.11	No Chk
400 023	Remby Bridge Fire Tax	310-	VTFN1508-1	13,590.43	98.43	330.41	13,358.45	No Chk
400 026	Wesley Chapel Fire Tax	636-	VTFN1508-1	11,159.34	69.29	278.62	10,950.01	No Chk
400 028	Waxhaw Fire Tax	634-	VTFN1508-1	7,291.58	57.10	181.39	7,167.29	No Chk
400 100	Schools	0-0		3,830.88	121.47	87.12	3,865.23	No Chk
400 101	Village of Marvin	1832-	VTFN1508-1	3,946.94	13.62	98.89	3,861.67	No Chk
400 200	City of Monroe	103-7	VTFN1508-1	142,409.51	1,180.40	3,053.76	140,536.15	No Chk
400 222	Monroe Downtown Service District	103-7	VTFN1508-2	19.86	.01	.33	19.54	No Chk
400 300	Town of Wingate	4064-	VTFN1508-1	4,829.71	43.88	108.67	4,764.92	No Chk
400 400	Town of Marshville	5861-	VTFN1508-1	6,684.78	58.19	139.79	6,603.18	No Chk
400 500	Town of Waxhaw	8268-	VTFN1508-1	50,460.14	402.81	1,262.53	49,600.42	No Chk
400 600	Town of Indian Trail	2924-	VTFN1508-1	65,295.45	554.55	1,582.69	64,267.31	No Chk
400 700	Town of Stallings	4860-2	VTFN1508-1	32,754.06	220.53	1,803.23	32,171.36	No Chk
400 800	Town of Weddington	7518-	VTFN1508-1	8,336.03	63.37	208.48	8,190.92	No Chk
400 900	Village of Lake Park	1833-	VTFN1508-1	6,831.99	61.26	168.89	6,724.36	No Chk
400 930	Town of Fairview	19458-	VTFN1508-1	806.35	6.40	19.28	793.47	No Chk
400 970	Village of Wesley Chapel	9262-	VTFN1508-1	1,294.73	8.76	32.25	1,271.24	No Chk
400 980	Town of Unionville	11530-	VTFN1508-1	1,093.29	6.27	26.81	1,072.75	No Chk
400 990	Town of Mineral Springs	10870-	VTFN1508-1	1,544.95	3.30	14.26	1,533.99	No Chk
400 999	Schools	0-0		953,989.81	6,756.37	22,972.98	937,773.20	No Chk

Interest Amount	842.62
A/P Totals	370,824.68
NO A/P Totals	1,608,805.39
Refund Totals	.00

Total Costs	47,365.56
A/P Totals	8,638.56
NO A/P Totals	38,727.00
Refund Totals	.00
Grand Totals	47,365.56

Attn: Debbie

RECEIVED  
COMMUNITY

SEP 10 2015

FINANCE OFFICE

END

Invoice Date	Invoice Number	Description	Invoice Amount
09/17/2015	VTFN1508-1	Cash Recvd NCVTS AUG/15	\$533.99

Vendor No.	Vendor Name	Check No.	Check Date	Check Amount
10870	TOWN OF MINERAL SPRINGS	00041981	09/21/2015	533.99



**County of Union**

500 North Main Street  
 Monroe, North Carolina 28112

Vendor Number    Check Date    Check Number  
 10870            09/21/2015    00041981

"This disbursement has been approved as required by the Local Government Budget and Fiscal Control Act."

**\$533.99**

Pay Five Hundred Thirty Three Dollars and 99 cents \*\*\*\*\*

To The            TOWN OF MINERAL SPRINGS  
 Order Of        PO BOX 600  
                      MINERAL SPRINGS NC 28108

**EFT COPY  
 NON-NEGOTIABLE**

AP



**County of Union**

500 North Main Street  
 Monroe, North Carolina 28112

10870  
 00041981

**ADDRESS SERVICE REQUESTED**

TOWN OF MINERAL SPRINGS  
 PO BOX 600  
 MINERAL SPRINGS NC 28108

July 2015 Collections

Summary

September 10, 2015

		ARTICLE 39	ARTICLE 40	ARTICLE 42	ARTICLE 43	ARTICLE 44	ARTICLE 45	ARTICLE 46	CITY HH	TOTAL
UNION	(Ad Valorem)	\$ 1,501,158.91	\$ 1,093,152.22	\$ 794,793.77	\$ -	\$ 203.12	\$ -	\$ -	\$ (231,039.01)	\$ 3,158,269.01
	FAIRVIEW	\$ 675.33	\$ 491.78	\$ 357.55	\$ -	\$ 0.09	\$ -	\$ -	\$ 504.36	\$ 2,029.11
	HEMBY BRIDGE	\$ -	\$ -	\$ -	\$ -	\$ -	\$ -	\$ -	\$ -	\$ -
	INDIAN TRAIL	\$ 53,680.43	\$ 39,090.39	\$ 28,421.29	\$ -	\$ 7.26	\$ -	\$ -	\$ 40,089.32	\$ 161,288.69
	LAKE PARK	\$ 4,838.45	\$ 3,523.38	\$ 2,561.73	\$ -	\$ 0.65	\$ -	\$ -	\$ 3,613.42	\$ 14,537.63
	MARSHVILLE	\$ 6,803.59	\$ 4,954.41	\$ 3,602.18	\$ -	\$ 0.92	\$ -	\$ -	\$ 5,081.03	\$ 20,442.13
	MARVIN	\$ 4,323.71	\$ 3,148.55	\$ 2,289.21	\$ -	\$ 0.59	\$ -	\$ -	\$ 3,229.02	\$ 12,991.08
	MINERAL SPRINGS	\$ 549.13	\$ 399.88	\$ 290.74	\$ -	\$ 0.07	\$ -	\$ -	\$ 410.12	\$ 1,649.94
	MINT HILL *	\$ 43.45	\$ 31.64	\$ 23.01	\$ -	\$ 0.01	\$ -	\$ -	\$ 32.45	\$ 130.56
	MONROE	\$ 151,931.28	\$ 110,637.20	\$ 80,440.55	\$ -	\$ 20.56	\$ -	\$ -	\$ 113,464.43	\$ 456,494.02
	STALLINGS *	\$ 28,299.95	\$ 20,608.18	\$ 14,983.51	\$ -	\$ 3.83	\$ -	\$ -	\$ 21,134.81	\$ 85,030.28
	UNIONVILLE	\$ 825.06	\$ 600.81	\$ 436.83	\$ -	\$ 0.11	\$ -	\$ -	\$ 616.16	\$ 2,478.97
	WAXHAW	\$ 43,453.50	\$ 31,643.08	\$ 23,006.61	\$ -	\$ 5.88	\$ -	\$ -	\$ 32,451.68	\$ 130,560.75
	WEDDINGTON *	\$ 8,719.31	\$ 6,349.45	\$ 4,616.47	\$ -	\$ 1.18	\$ -	\$ -	\$ 6,511.72	\$ 26,198.13
	WESLEY CHAPEL	\$ 1,186.44	\$ 863.97	\$ 628.16	\$ -	\$ 0.16	\$ -	\$ -	\$ 886.05	\$ 3,564.78
	WINGATE	\$ 4,036.38	\$ 2,939.32	\$ 2,137.08	\$ -	\$ 0.55	\$ -	\$ -	\$ 3,014.44	\$ 12,127.77

North Carolina Utility Sales Tax Distribution - 4/1/15 - 6/30/15 (FY2014-15 Accrued)

9/15/2015

Prefix	City/County	Sales Tax on Piped Natural Gas	Sales Tax on Electricity	Sales Tax on Telecommunication Services	Sales Tax on Video Programming	Total Distribution
County of	Union	\$ -	\$ -	\$ -	\$ 130,484.50	\$ 130,484.50
Town of	Fairview	\$ 7,694.16	\$ 24,227.35	\$ 9,149.00	\$ 2,118.02	\$ 43,188.53
Town of	Hemby Bridge	\$ 3,441.63	\$ 9,084.99	\$ 4,019.26	\$ 3,905.54	\$ 20,451.42
Town of	Indian Trail	\$ (334,227.17)	\$ 263,901.08	\$ 25,536.44	\$ 77,999.57	\$ 33,209.92
Town of	Lake Park	\$ 18,036.32	\$ 19,554.09	\$ 495.02	\$ 5,355.34	\$ 43,440.77
Town of	Marshville	\$ (47.51)	\$ 38,282.66	\$ 6,431.55	\$ 3,225.53	\$ 47,892.23
Town of	Marvin	\$ 61,443.63	\$ 37,364.31	\$ 16,040.29	\$ 17,048.32	\$ 131,896.55
Town of	Mineral Springs	\$ 2,407.37	\$ 50,513.69	\$ 1,445.63	\$ 5,359.21	\$ 59,725.90
City of	Monroe	\$ (30,958.08)	\$ 668,794.24	\$ 95,518.02	\$ 57,724.89	\$ 791,079.07
Town of	Stallings	\$ 71,351.30	\$ 134,588.84	\$ 2,429.25	\$ 44,487.16	\$ 252,856.55
Town of	Unionville	\$ 6,533.00	\$ 37,117.09	\$ 16,121.67	\$ 7,019.51	\$ 66,791.27
Town of	Waxhaw	\$ 34,358.63	\$ 118,813.63	\$ 18,554.87	\$ 43,804.78	\$ 215,531.91
Town of	Weddington	\$ 55,885.22	\$ 73,661.17	\$ 2,016.73	\$ 24,650.50	\$ 156,213.62
Village of	Wesley Chapel	\$ 27,466.47	\$ 44,031.32	\$ 2,488.83	\$ 24,597.78	\$ 98,584.40
Town of	Wingate	\$ -	\$ 25,058.76	\$ 5,039.08	\$ 5,577.20	\$ 35,675.04

# MINERAL SPRINGS GREENWAY TRAIL ACCESSIBILITY

NOVEMBER 6, 2015

SHEET NO. / TITLE

COVER	L0.00
McNEELY RD ACCESS	L1.10
CROFTON DR ACCESS	L1.20

PREPARED FOR:  
TOWN OF MINERAL SPRINGS

3506 SOUTH POTTER ROAD  
MINERAL SPRINGS, NC 28112

MAILING ADDRESS:  
P.O. BOX 600  
MONROE, NC 28108  
P: 704.243.0505  
F: 704.243.0506



PROJECT LOCATION / SHEET INDEX SCALE: 1" = 500'-00" NORTH



PREPARED BY:



**STEWART**

290 S. COLLEGE ST., STE 720  
CHARLOTTE, NC 28202  
704.334.7925  
FIRM LICENSE # C-1051  
www.stewartinc.com  
PROJECT # X15043



# STEWART

421 FAYETTEVILLE ST. STE. 400  
RALEIGH, NC 27601  
T: 919.382.8750  
FIRM LICENSE #: C-1051  
www.stewartinc.com  
PROJECT #: X15043

Client:  
**TOWN OF MINERAL SPRINGS**  
3506 SOUTH POTTER ROAD  
MINERAL SPRINGS, NC 28112

MAILING ADDRESS:  
P. O. BOX 600  
MONROE, NC 28108  
P: 704.243.0505  
F: 704.243.0506

## Project: MINERAL SPRINGS GREENWAY TRAIL ACCESSIBILITY

Vicinity map:

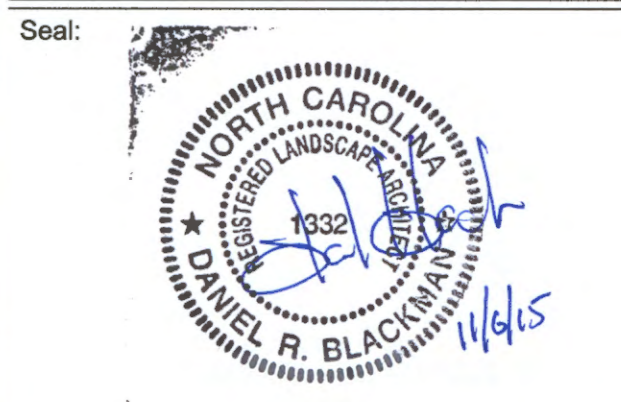

Issued for:  
**SCHEMATIC DESIGN**

No.	Date	Description

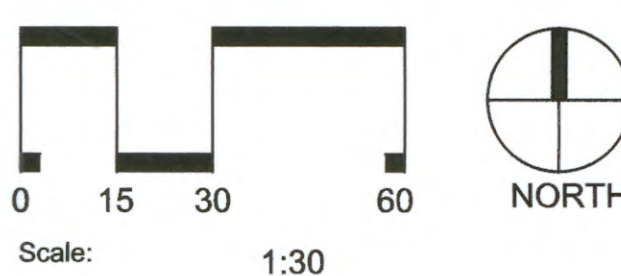

Title:  
**McNEELY RD ACCESS**

Project number: X15043 Sheet:  
Date: 11.06.2015  
Drawn by: RSC  
Approved by: DB **L1.10**

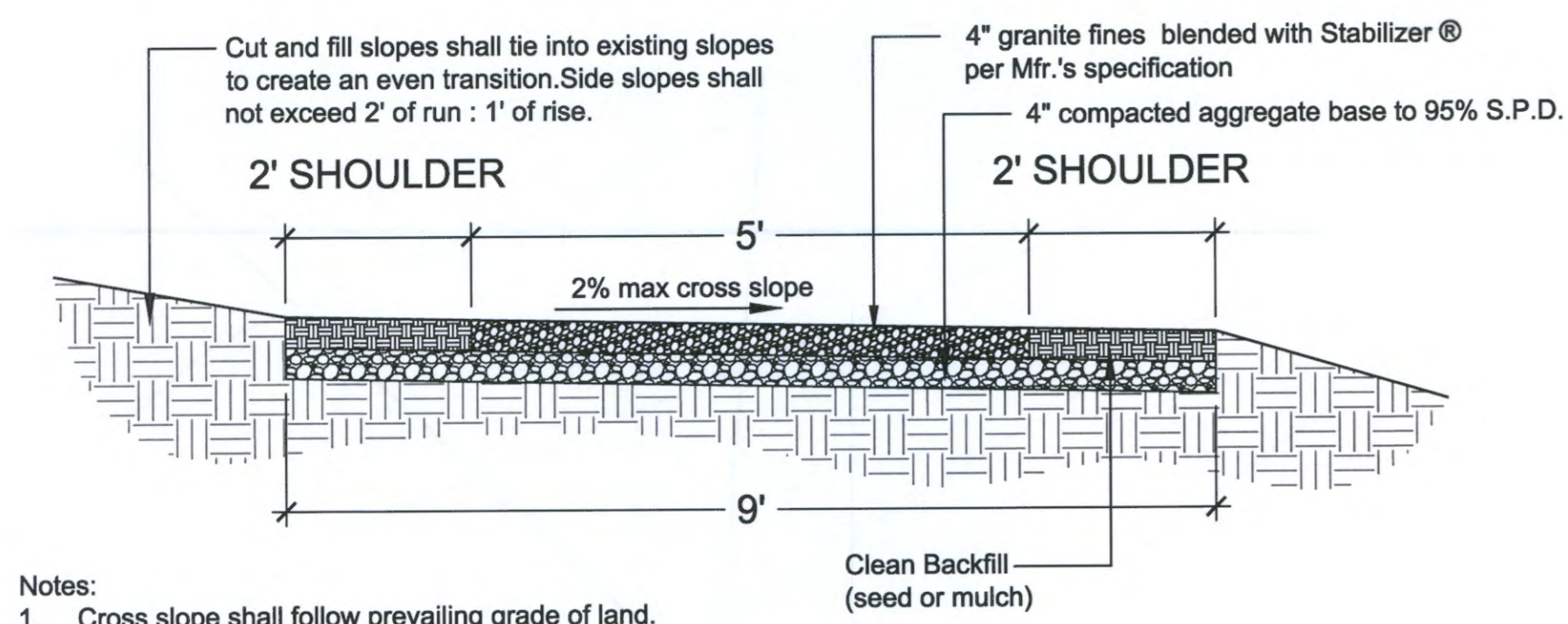

- Notes:
1. Cross slope shall follow prevailing grade of land.
  2. Maximum longitudinal slope : less than 5%
  3. Contractor is responsible for re-establishing all slopes disturbed by construction.

### STABILIZED GRANITE FINES TRAIL DETAIL SCALE: NTS

SEPTIC DRAINFIELD (UN-USED)

TOWN OF MINERAL SPRINGS  
PIN - 06060062

REO FUNDING SOLUTIONS LLC  
PIN - 06060063

NOTE: REMOVE (4)  
PICNIC TABLES ALONG  
EXISTING TRAIL

### PROPOSED PICNIC AREA

COMPACTED GRANITE FINES SURFACE. MAX. SLOPE: 2% ALL DIRECTIONS. BLEND FINE WITH STABILIZER (R).  
2- ACCESSIBLE PICNIC TABLES  
2- STANDARD PICNIC TABLES

PROPOSED ACCESSIBLE TRAIL (260 LF)  
5' MIN. WIDTH, COMPACTED GRANITE FINES SURFACE. MAX. LONG. SLOPE 5%, MAX. CROSS SLOPE 2%. BLEND FINES WITH STABILIZER (R).

PROPOSED PARKING LOT AND TRAILHEAD IMPROVEMENTS (SEE ENLARGEMENT)

EXIST. SEDIMENT BASIN

TOWN OF MINERAL SPRINGS  
PIN - 06060001

EXISTING GRAVEL PARKING

EXISTING GREENWAY TRAIL (NATURAL SURFACE)

STREAM

FINCHER, TIMOTHY  
PIN - 06060005A

McNEELEY RD 1325

FEMA LINE

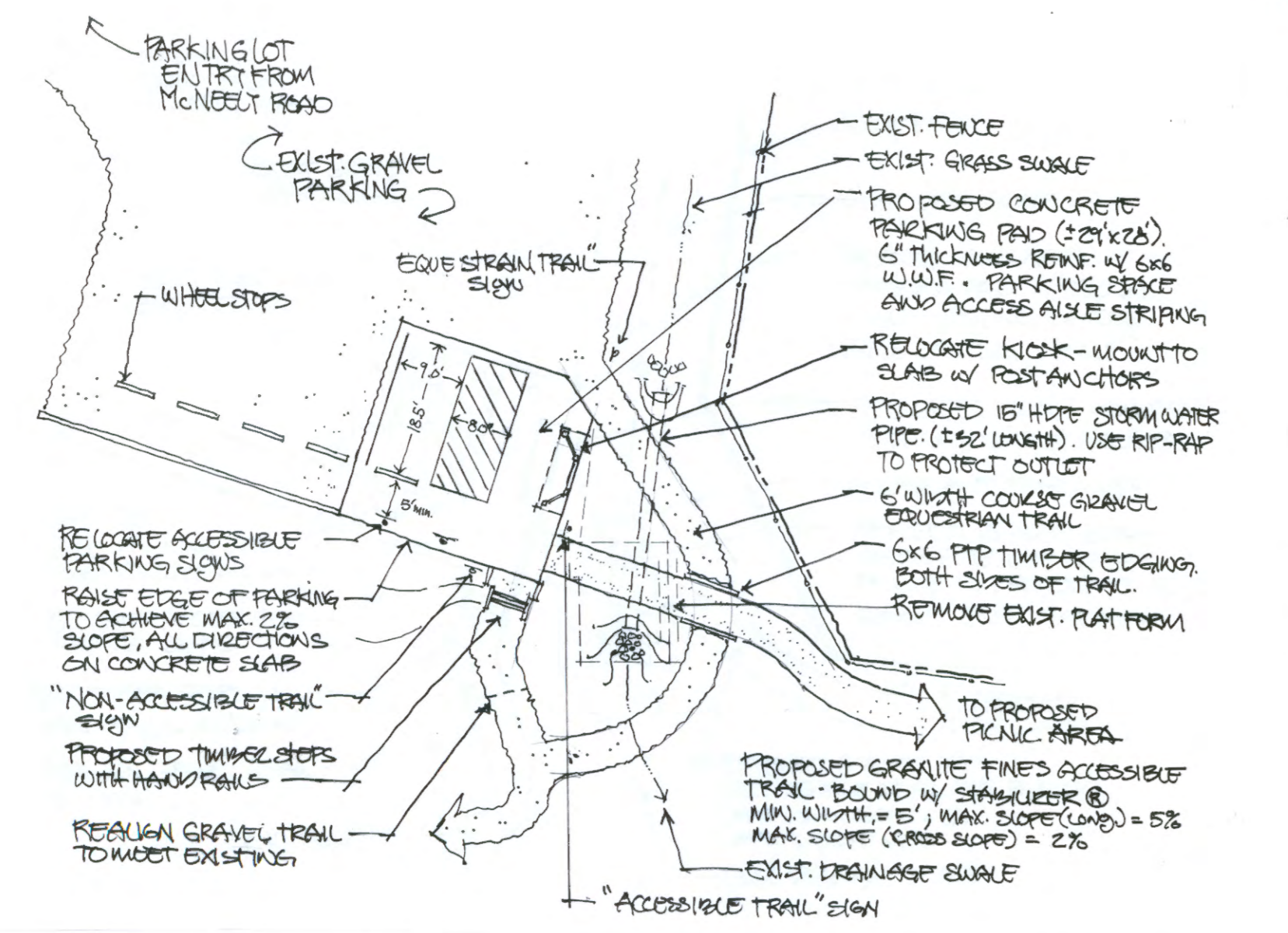

### PARKING LOT/TRAILHEAD ENLARGEMENT SCALE: 1"=20'

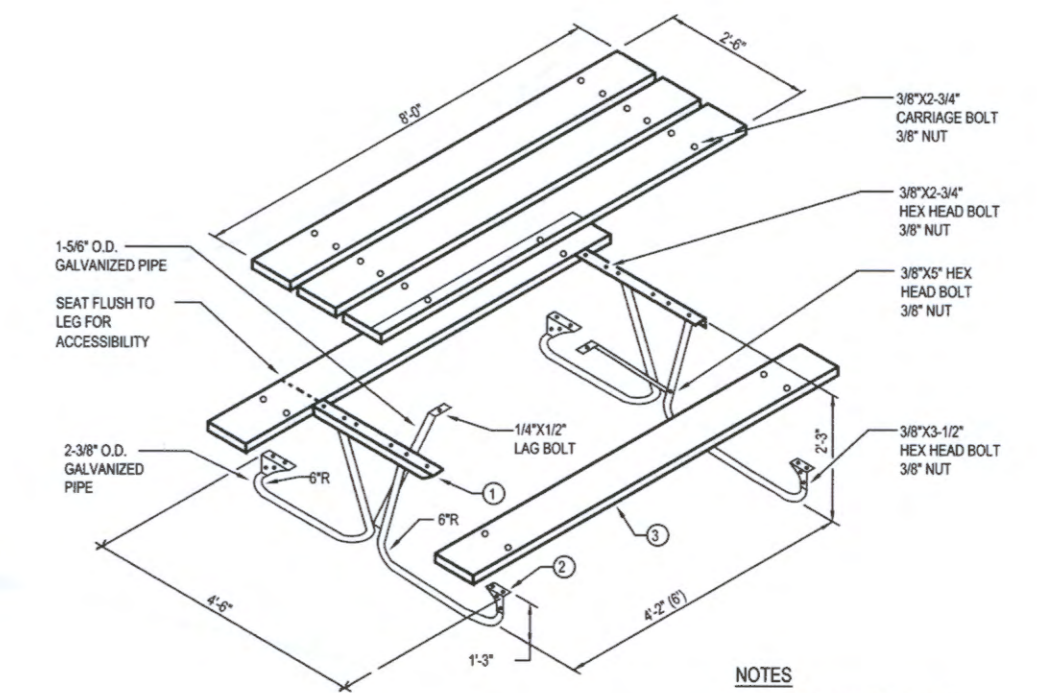

- NOTES
1. TOP BOARD SUPPORTS-(2 REQ'D)  
1" SQUARE X 1 1/2" DIA-4"x12" GALVANIZED STEEL.
  2. SEAT BOARD SUPPORTS-(4 REQ'D)  
1" SQUARE X 1 1/2" DIA-12"x12" GALVANIZED STEEL.
  3. SEAT BOARDS & TOP BOARDS-(5 REQ'D)  
2X10 #1 SOUTHERN YELLOW PINE. ALL EDGES SHALL BE RASPED.
  4. ALL HARDWARE TO BE HOT DIP GALVANIZED STEEL.
  5. ALL WOOD SHALL BE PRESSURE TREATED.

### ACCESSIBLE PICNIC TABLE SCALE: NTS

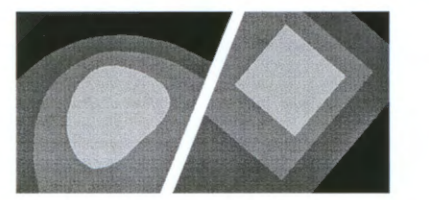

**STEWART**

421 FAYETTEVILLE ST. STE 400 FIRM LICENSE #: C-1051  
RALEIGH, NC 27601 www.stewartinc.com  
T 919.380.8750 PROJECT #: X15043

Client:

**TOWN OF MINERAL SPRINGS**  
3508 SOUTH POTTER ROAD  
MINERAL SPRINGS, NC 28112

MAILING ADDRESS:  
P.O. BOX 600  
MONROE, NC 28108  
P: 704.243.0505  
F: 704.243.0506

Project:

**MINERAL  
SPRINGS  
GREENWAY  
TRAIL  
ACCESSIBILITY**

Vicinity map:

Seal:

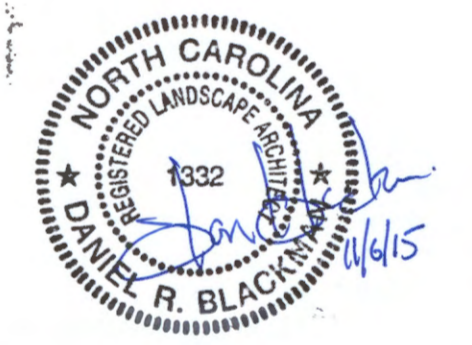

Issued for:

**SCHEMATIC DESIGN**

No.	Date	Description

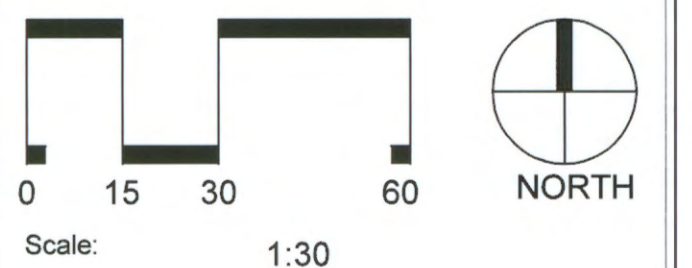

Title:  
**CROFTON DR. ACCESS**

Project number: X15043 Sheet:  
Date: 11.06.2015  
Drawn by: RSC  
Approved by: DB **L1.20**

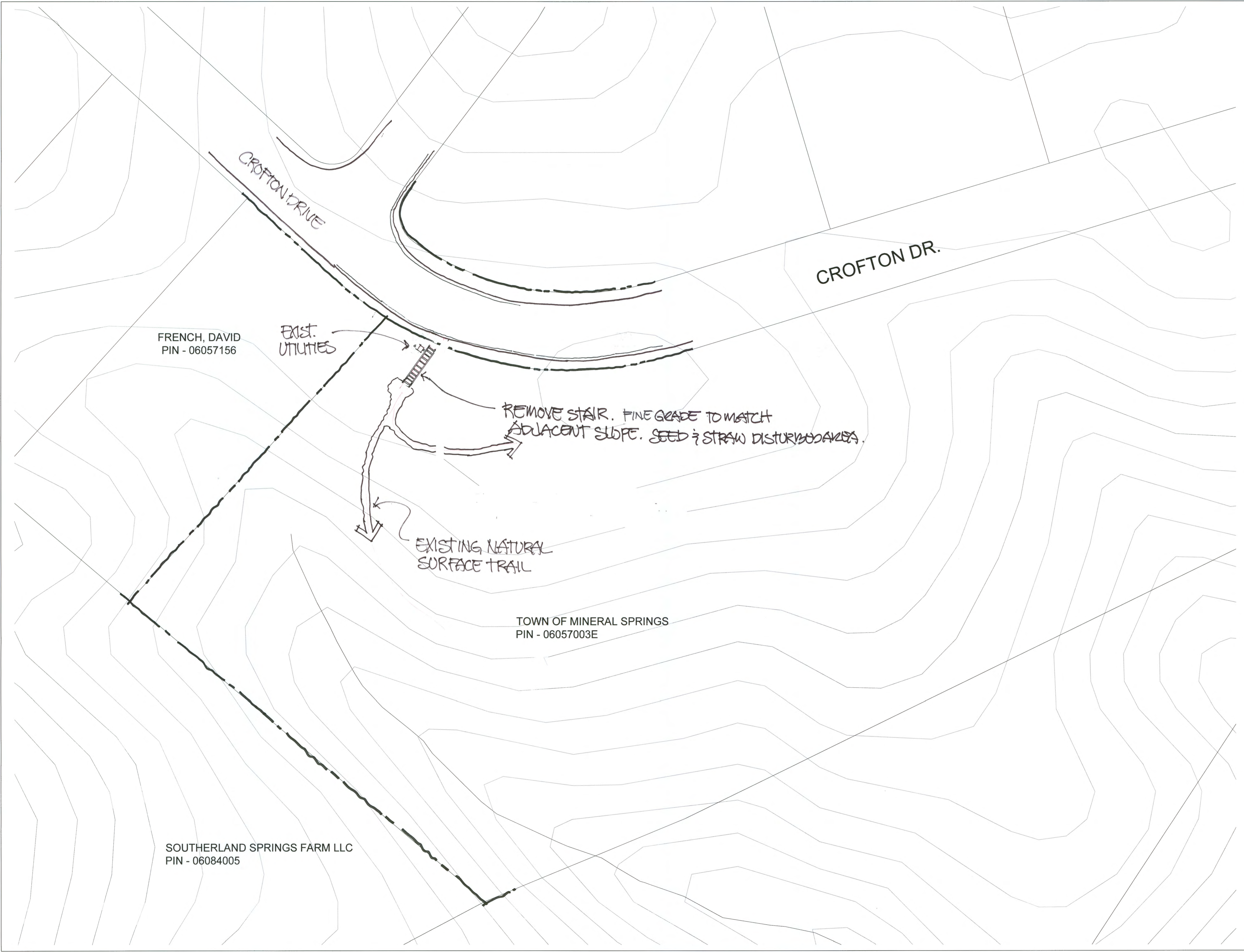



## 2016 Mineral Springs Holiday Schedule - DRAFT

The following public holidays are established for the Town of Mineral Springs employees. The town hall will officially be closed on the days indicated below.

<b>Friday, January 1, 2016</b>	New Year's Day
<b>Monday, January 18, 2016</b>	Birthday of Martin Luther King, Jr.
<b>Monday, February 15, 2016</b>	Washington's Birthday
<b>Monday, March 28, 2016</b>	Easter Monday
<b>Monday, May 30, 2016</b>	Memorial Day
<b>Monday, July 4, 2016</b>	Independence Day
<b>Monday, September 5, 2016</b>	Labor Day
<b>Monday, October 10, 2016</b>	Columbus Day
<b>Friday, November 11, 2016</b>	Veterans Day
<b>Thursday, November 24, 2016</b>	Thanksgiving Day
<b>Friday, November 25, 2016</b>	Thanksgiving Day Holiday
<b>Friday, December 23, 2016</b>	Christmas Eve
<b>Monday, December 26, 2016</b>	Christmas Day
<b>Friday, December 30, 2016</b>	New Year's Eve
<b>Monday, January 2, 2017</b>	New Year's Day

Presented to the Mineral Springs Town Council on 11/12/15