

**Town of Mineral Springs
Mineral Springs Town Hall
3506 Potter Road S ~ Mineral Springs
Mineral Springs Town Council
Regular Meeting
November 10, 2022 ~ 7:30 P.M.
AGENDA**

- 1. Opening**
The meeting will be called to order, an invocation will be delivered, and the Pledge of Allegiance will be recited.
- 2. Public Comments**
The town council will hear comments from members of the public on any matters of interest to them during this ten-minute period.
- 3. Consent Agenda – Action Item**
 - A. Approval of the October 13, 2022 Regular Meeting Minutes
 - B. Acceptance of the September 2022 Union County Tax Report
 - C. Acceptance of the September 2022 Finance Report
- 4. Consideration of Approving the Lighting Plan for God’s Temple of Zion’s Soccer Field – Action Item**
The council will consider approving the lighting plan for God’s Temple of Zion’s soccer field located at 5902 McNeely Road.
- 5. Consideration of Granting Funds to the D. Coffey Foundation for Athletics and Education for an After-School Program – Action Item**
Dr. Delice Coffey and Mr. John Tillman will make a presentation and request grant funding in the amount of \$56,194 to implement a Social-Emotional Readiness Program for children in Grades K - 5.
- 6. Consideration of Project Ordinance (O-2022-05) – Action Item**
The council will consider approving a project ordinance to authorize funding for the D. Coffey Foundation’s Social-Emotional Readiness Program.
- 7. Consideration of the 2023 Town Hall Holiday Schedule – Action Item**
The council will consider approving the 2023 Town Hall Holiday Schedule.
- 8. Staff Updates**
The staff will update the council on any developments that may affect the town.
- 9. Other Business**
- 10. Adjournment**

**Draft Minutes of the
Mineral Springs Town Council
Regular Meeting
October 13, 2022 – 7:30 p.m.**

The Town Council of the Town of Mineral Springs, North Carolina, met in Regular Session at the Mineral Springs Town Hall located at 3506 Potter Road S, Mineral Springs, North Carolina, at 7:30 p.m. on Thursday, October 13, 2022.

Present: Mayor Frederick Becker III, Mayor Pro Tem Jerry Countryman, Councilwoman Valerie Coffey, Councilwoman Janet Critz, Councilwoman Lundeen Cureton, and Councilman Jim Muller.

Absent: Councilwoman Bettylyn Krafft.

Staff Present: Town Clerk/Zoning Administrator Vicky Brooks, Attorney Bobby Griffin, and Administrative Assistant/Deputy Town Clerk Maurice Norman.

Visitors: Rev. Jimmy H. Bention, Sr. and William Colon Moore.

1. Opening

With a quorum present at 7:31 p.m. on October 13, 2022, Mayor Becker called the Regular Town Council Meeting to order.

Councilwoman Critz delivered the invocation.

Pledge of Allegiance.

2. Public Comments

There were no public comments.

3. Consent Agenda – Action Item

Councilman Countryman motioned to approve the consent agenda containing the numbering amendment in the July 2022 Regular Meeting Minutes, the September 8, 2022 Regular Meeting Minutes, the August 2022 Union County Tax Report, and the August 2022 Finance Report and Councilwoman Coffey seconded. The motion passed unanimously. Ayes: Coffey, Countryman, Critz, Cureton, and Muller. Nays: None.

4. Union County School Board Bond Package Presentation

Union County School Board Member Rev. Jimmy H. Bention, Sr. and Assistant Superintendent for Administration and Operations Mr. William Colon Moore made a presentation to the council about the upcoming vote on a bond package.

Mr. Bention began the presentation.

- o There have been 30 new construction and renovation projects over the last couple of decades. The current bond package is \$134,405,000 to replace two aging schools.
- o New buildings will be constructed for Forest Hills High School and East Elementary School, which were built in the fifties and sixties.
- o The vote will occur on November 8th; early voting starts next week.
- o The school board is encouraging people to go forth and vote.
- o UCPS has more than 8,000,000 in facility needs (renovations, upgrades, and future planning).

- UCPS is appreciative of what the county commissioners have allowed them to put before the citizens on this bond.
- UCPS wants to be able to remove mobile classrooms that are at the end of their cycle.
- East Elementary School is well kept, but it is old. Rev. Bention encouraged council to take a visit and have their citizens visit.
- Mr. Bob Moore and his team as well as the facilities people do an outstanding job of taking what exists and making it look good, but that does not minimize the age.
- Rev. Bention pointed out the schematic [in the agenda packet] of the futuristic view of East Elementary.
- The cost of the new East Elementary School is just north of \$38,000,000.
- The cost for Forest Hills is just north of \$95,000,000.
- East Elementary School and Forest Hills High School will be two-story facilities.
- UCPS is looking to address new construction facilities, upgrades, and renovations with their 10-year long-term capital planning with a successful bond.

Mr. Moore continued the presentation.

- Mr. Moore clarified the bond funds could be spent on construction, renovations, land acquisition, capital items, insured equipment, and contractors.
- No land acquisition is needed for the East Elementary School or Forest Hills High School projects; land was purchased through some funds years ago for Forest Hills.
- Bonds can not be used to pay Union County Public Schools salaries.
- UCPS submitted approximately 15 projects to the county commissioners for over \$160,000,000 worth of needs for the next two years. It was the intention to have all those projects on the bond. The county commissioners selected these two projects, which will be put up for voters to vote on the funding.
- Funding through bonds is the most economical way for taxpayers to fund projects.
- The estimated tax increase would be approximately \$17.30 on a \$100,000 property, if the bond passes.
- Capital Improvement Projects information can be found on the UCPS website.

Councilwoman Coffey asked if the construction of Forest Hills High would eliminate all trailers.

Mr. Moore responded yes, at Forest Hills High School and East Elementary. Forest Hills currently has an enrollment of approximately 750 and the capacity of students in the new school will be 1200, with the core capacity of 1500. What that means is the school can seat 1200 students, but the cafeteria, gym, media center, and common areas will be able to accommodate 1500 students.

Councilwoman Coffey commented that it was important to look at building for the future need, because sometimes schools have been built that were at capacity when the doors were unlocked, and they were putting trailers on the property.

Councilwoman Critz shared a story. In 2004, her father moved to the Outer Banks for an extended period of time and Marc Basnight was a member of the North Carolina Senate at the time and a resident of that area. On one of Councilwoman Critz's visits there she had a conversation with Sen. Basnight in which he took her on a tour of their brand-new elementary school that was built without one penny of taxpayer money. This was exciting for Councilwoman Critz until she realized how entangled it could be on a legal basis. The school was built with what would be termed as "transfer fees and impact fees", which are things that have to be approved by the legislature. In 2004, Councilwoman Critz volunteered to represent Mineral Springs as the liaison with the county to create a public facilities ordinance study process. Tens of thousands of dollars were spent hiring professionals to come work with the group; the group worked for over a year. There was an ordinance adopted by a three to two vote by the county commissioners. Immediately after adoption,

the county was sued by a developer. Councilwoman Critz further commented she thought there were options to debt, because she is not a fan of bonds and never has been. In most cases, they are not really upfront, and people don't understand exactly that it is a loan or the amount of interest or that in many cases their children or grandchildren (or both) might still be paying off these bonds. Councilwoman Critz encouraged the UCPS to look for alternatives to bonds, or to look for other ways through compromise during this time. Councilwoman Critz added that the developer building all the homes up and down Cuthbertson donated land and she looks at free land the same way she would look at a free puppy. There is nothing free about it at all, it cost the county over \$500,000 (in 2000) to just prepare the land to house the facilities, recreational fields, and the buildings. The builders that created the pressure on the infrastructure and made lots of money basically got away with and continue to get away with no input; it does not cost them a thing to over-impact a community. Councilwoman Critz again encouraged UCPS to explore what other options there might be out there.

Councilwoman Coffey commented that she hoped and prayed the bond passed, because she knows the need at Forest Hill and East Elementary. Councilwoman Coffey encouraged people to go visit the school, so they would understand what the children are having to deal with. "I promise you; we may do something else for the future, but for today, we need money, and we need it in construction of these schools," Councilwoman Coffey stated.

5. Consideration of Financial and Internal Control Policy – Action Item

Mayor Becker explained the Financial and Internal Control Policy was broken up into three sections, which is a little bit misleading. Mayor Becker referred to his first memo, which applied to agenda items 5 and 6, and explained the reason it was two separate agenda items was because agenda item 5 was the town's own Finance and Internal Controls Policy and it was not a template from the Institute of Government, it is something the town has been operating under. The council has adopted pieces of it and Mayor Becker has reported on other pieces of it. With Mineral Springs being a small unit of government, the Local Government Commission put out guidelines they suggested the town follow. Back in 2015, Mayor Becker did respond to them saying the town was adopting several of those suggestions, with overlapping duties with other people to look at transactions. As part of the requirement to accept or to start spending the federal money, the town must have an Internal Control Policy adopted. The town has one, but it was never formally adopted, so Mayor Becker dressed up everything that the town pieced together in the past seven or eight years and that is the policy the council is seeing. Mayor Becker explained he made it a separate agenda item, because the council has a little more discretion in there. This is what the council has given Mayor Becker as guidance to do over the years, and some of it came from the Local Government Commission. Mayor Becker wanted to make sure the council had a chance to read over the policy he was asking them to adopt under agenda item 5, the Financial and Internal Control Policy, to make sure that it looked like what they see the town doing and what they have endorsed for the finance office. In the long-term, there is a benefit for a future finance officer to have a written template to go by as it will help the learning curve for somebody who will someday come in to take the finance officer job. Mayor Becker mentioned that auditors tend to recommend a finance policy, because they work hand-in-hand with the Local Government Commission.

Councilwoman Critz motioned to approve the Financial and Internal Control Policy and Councilman Muller seconded. The motion passed unanimously. Ayes: Coffey, Countryman, Critz, Cureton, and Muller. Nays: None.

6. Consideration of American Rescue Plan Act Policies – Action Item

Mayor Becker explained item numbers 6.1 through 6.5 are "boiler plate legalese," which came from the Coates' Canons blog that is published by the scholars at the School of Government [SOG]. The scholars have drawn up these five policies the Treasury Department requires municipalities to have in force if they are spending any federal funds. In agenda item number 7, the council will be starting to move the federal funds out from under the federal umbrella and creating local funds out of them by "magic." In order to do any of that, the council will have to adopt items 6.1 through 6.5. Mayor

Becker used the guidelines from Kara Millonzi [of the SOG]. Step one is to adopt the town's financial policy locally, which the town has been doing with its financial administration and accounting system for years. Step 2 is to adopt and implement the five general compliance policies that are based on federal guidelines: Records Retention, which is special to this (above and beyond the one that Vicky puts forth), it is specifically for anything that this money is used for and the records have to be retained for five years after the end of the grant period (2026); Eligible Use is a lot of "gobbledygook" that is very specific, which is listed in 6.2; Allowable cost (which is something Mayor Becker had never heard of until he started reading it over); Civil Rights Compliance, which Mayor Becker believed the town had signed onto when it agreed to some civil rights compliance requirements when the CDBG participation was adopted, it is a federal policy, but the town does have to assert it will be following non-discrimination policies.

Finally there was the Conflict of Interest Policy, which must be adopted even though it won't directly apply to the type of expenditures the town will be making (no third parties, no contractors, no vendors, because the town will be paying themselves back for previously paid salaries internally, which is allowed). Once the town has paid that money back, that money is the town's money and is no longer bound by the federal requirements. It has been magically reinstated to the town's general fund, but the policies still have to be adopted to get to that point.

Mayor Becker explained that the Conflict of Interest Policy has step-by-step guidelines to test for conflicts of interest, although the town was not ever going to have to implement that. The Eligible Use Policy and the Allowable Cost Policy have checklists the finance officer is required to execute for any particular expenditure. "Does it meet this? Does it meet this? Does it meet that?" Mayor Becker stated he wanted to bring to the council's attention those checklists as part of that policy. The finance officer must sign off and say "yes", it has complied with the Eligible Use Policy and the Allowable Cost Policy.

Mayor Becker recommended the council adopt the five required American Rescue Plan Act policies.

Councilwoman Critz motioned to adopt agenda items 6.1 through 6.5 and Councilman Muller seconded. The motion passed unanimously. Ayes: Coffey, Countryman, Critz, Cureton, and Muller. Nays: None.

7. Consideration of Adopting O-2022-01 Amending O-2021-02 – Action Item

Mayor Becker reminded the council and referred to his memo in the agenda packet that explained when they started talking about the federal money (\$270,000). There had been concern, because it had to be spent by December 31, 2026, and the town did not think they could use it for roads (local match, or for building a sidewalk, or the community center (which could not be started until later). The town was just sitting on the federal money that had to be spent on things they did not necessarily want to spend it on, just because they had to do it. Mayor Becker explained that the US Treasury had later modified the requirements, so now if the town spent the money on "paying ourselves back" for things that had already been spent, the money would be cleared up and it is the town's money. This has to be done by a grant project ordinance, and the ordinance that had been presented to the council was formatted from the template (almost exactly) from Kara Millonzi's blog. The ordinance is a lot like a Capital Project Ordinance the council has adopted in the past, because it is transferring money out of one fund and allocating it to prior payroll expenditures. "That's it"; it is no longer federal money. Mayor Becker noted at the end of the Grant Project Ordinance there were two questionnaires in red, blue, and black, which were the Eligible Use and Allowable Cost policy checklists where he had gone over and explained that it either met the requirements or it was not applicable. The background of why that was legally complying with the policies was included. If the council adopts the ordinance, Mayor Becker will transfer \$230,669.86 out of the special restricted project fund into the general fund as a reimbursement of salaries, which will leave the town with about \$37,000 of federal funds. Mayor Becker further explained one of the examples Kara Millonzi and the School of Government proposed showed "Municipality X" using the funds to pay future expenses and doing that all in one ordinance. As Mayor Becker stated in his memo, it is easier from an accounting standpoint to wait until the town knows the exact amount they have spent and allocate

the rest at the end of this fiscal year. Mayor Becker stated he talked to the town auditor and there is not a problem with either way the town does it.

Mayor Becker mentioned an issue that does come up is that once you accept more than \$100,000 or spend more than \$100,000 in federal money, you have to have what is called a “Yellow Book Audit”, which is simply a procedure at the auditor’s about certifying their impartiality in preparing financial statements and then auditing the same statements. Mayor Becker confirmed that Kendra [Gangel] (town auditor) felt that she does not have to do anything differently as long as she can certify, that will work. If the town had more than \$750,000, there is something that is called a “single audit”, which is much more complicated. Kendra is aware of what the town is doing, and everything seems to be on the up and up. The next step is to adopt the Project Ordinance if the council choses to reimburse the town for the payroll expenses from March 3, 2021 through September 30, 2022.

Councilwoman Critz asked if there was nothing in the future the council had to do once this [ordinance adoption] was done.

Mayor Becker responded, “for that money, nothing”, but he will have to file another report in April of 2023 to the U.S. Treasury. Mayor Becker will do his own internal reporting, the auditor reports the transfer, verifies the transfers, and then the money is just in the bank.

Councilwoman Critz motioned to consider adopting O-2022-01 and amending O-2021-02 and Councilwoman Coffey seconded. The motion passed unanimously. Ayes: Coffey, Countryman, Critz, Cureton, and Muller. Nays: None.

The ordinance (O-2022-01) is as follows:

STATE OF NORTH CAROLINA
TOWN OF MINERAL SPRINGS

AN ORDINANCE AMENDING O-2021-02: TO APPROPRIATE AND SPEND FEDERAL CORONAVIRUS STATE AND LOCAL FISCAL RECOVERY FUND (CSLFRF) REVENUES UNDER H.R. 1319, THE AMERICAN RESCUE PLAN ACT OF 2021 (ARPA) O-2022-01

BE IT ORDAINED by the town council of the Town of Mineral Springs, North Carolina that, pursuant to Section 13.2 of Chapter 159 of the General Statutes of North Carolina, the following grant project ordinance is hereby adopted, amending Grant Project Ordinance O-2021-02, adopted on August 12, 2021:

Section 1: This ordinance is to establish a budget for a project or projects to be funded by the Coronavirus State and Local Fiscal Recovery Fund (CSLFRF) revenues of H.R. 1319 American Rescue Plan Act of 2021 (ARPA). The Town of Mineral Springs has received the full allocation CSLFRF revenues in the amount of \$270,618.75. These funds may be used for the following categories of expenditures, to the extent authorized by state law.

1. Support public health expenditures, by funding COVID-19 mitigation efforts, medical expenses, behavioral healthcare, and certain public health and safety staff;
2. Address negative economic impacts caused by the public health emergency, including economic harms to workers, households, small businesses, impacted industries, and the public sector;
3. Replace lost public sector revenue, using this funding to provide government services to the extent of the reduction in revenue experienced due to the pandemic;
4. Provide premium pay for essential workers, offering additional support to those who have borne and will bear the greatest health risks because of their service in critical infrastructure sectors; and,
5. Invest in water, sewer, and broadband infrastructure, making necessary investments to improve access to clean drinking water, support vital wastewater and stormwater infrastructure, and to expand access to broadband internet.

Section 2: The town has elected to take the standard allowance, as authorized by CFR Part 35.6(d)(1) and expend all its ARP/CSLFRF revenues for the provision of government services. Specifically, this ordinance authorizes reimbursement for salaries and benefits paid from March 3, 2021 through September 30, 2022. The Finance Officer has determined that the salaries of the Clerk, Deputy Clerk, Finance Officer, Planning Director, and Deputy Tax Collector are allowable, and that LGERS pension contributions, NCLM Health Benefits Trust contributions, and FICA contributions for those employees are allowable. The 4.7% LGERS accrued pension liability employer contribution for the Clerk, Finance Officer, and Planning Director is considered a “pension deposit” and is disallowed.

Internal Project Code	Project Description	Expenditure Category (EC)	Cost Object	Appropriation of ARP/CSLFRF Funds
001	Finance, Clerk, Tax, and Planning - March 3, 2021 through March 31, 2022	6.1	Salaries	\$131,386.76
002	Finance, Clerk, Tax, and Planning – March 3, 2021 through March 31, 2022	6.1	Benefits	\$24,527.21
003	Finance, Clerk, and Planning – April 1, 2022 through September 30, 2022	6.1	Salaries	\$62,723.61
004	Finance, Clerk, and Planning – April 1, 2022 through September 30, 2022	6.1	Benefits	\$12,032.28
	Unassigned			\$39,948.89
	TOTAL			\$270,618.75

Section 3: The following amount is appropriated for the project(s) and authorized for expenditure:

Section 4: The following revenues are anticipated to be available to complete the project:

CSLRF Revenues \$270,618.75

Section 5: The Finance Officer is hereby directed to maintain sufficient specific detailed accounting records to satisfy the requirements of the grantor agency and the grant agreements, including payroll documentation, in accordance with 2 CFR 200.430, 2 CFR 200.431, and the town’s Uniform Guidance allowable Costs and Cost Principles Policy.

Section 6: The Finance Officer is hereby directed to report the financial status of the project to the governing board on a quarterly basis.

Section 7: Copies of this grant project ordinance shall be furnished to the Budget Officer, the Finance Officer and the Municipal Clerk.

Section 8: This grant project ordinance is effective as of March 3, 2021 and expires on December 31, 2026, or when all the ARP/CSLFRF funds have been obligated and expended by the town, whichever occurs sooner.

ADOPTED this 13th day of October, 2022.

Frederick Becker III, Mayor

Attest:

Vicky A. Brooks, CMC, Clerk

8. Consideration of Adopting O-2022-02, O-2022-03, and O-2022-04 – Action Item

Mayor Becker explained this came to Vicky’s attention, because the town had recently adopted an ordinance enacting a speed limit change on Shannon Road and nothing ever happened. Someone from DOT contacted Vicky and said, “you know that ordinance has never gone into effect, because you didn’t repeal the old one.” Mayor Becker mentioned DOT never told the town to repeal the speed limit. Ms. Brooks dealt with the NCDOT people, and it finally became clear what was going on and they had really not sent the town something to repeal, which is done with a concurring ordinance. NCDOT came up with what the repeal would have been, so the town can repeal the old one, and then adopt the new one.

Councilwoman Coffey motioned to repeal ordinance O-2019-01 and adopt O-2022-02 and Councilwoman Cureton seconded. The motion passed unanimously. Ayes: Coffey, Countryman, Critz, Cureton, and Muller. Nays: None.

The ordinance (O-2022-02) is as follows:

STATE OF NORTH CAROLINA
TOWN OF MINERAL SPRINGS

**AN ORDINANCE REPEALING ORDINANCE O-2019-01
O-2022-02**

WHEREAS, the Town Council of Mineral Springs finds that “AN ORDINANCE DECLARING SPEED LIMIT MODIFICATION CONCURRING WITH THE DEPARTMENT OF TRANSPORTATION ORDINANCE, O-2019-01”, adopted March 12, 2020, enacting a

speed limit on SR 1328 concurring with the North Carolina Department of Transportation contained an inaccurate road description and it is in the public interest to repeal it;

NOW, THEREFORE BE IT ORDAINED by the Town Council of the Town of Mineral Springs, North Carolina, the following:

SECTION 1. Mineral Springs Ordinance O-2019-01, entitled "AN ORDINANCE DECLARING SPEED LIMIT MODIFICATION CONCURRING WITH THE DEPARTMENT OF TRANSPORTATION ORDINANCE" is hereby repealed.

SECTION 2. This ordinance shall be effective as of the date of its adoption.

ADOPTED this 13th day of October, 2022. Witness my hand and official seal:

Frederick Becker III, Mayor

Attest:

Vicky A. Brooks, CMC, Town Clerk

Councilman Muller motioned to adopt ordinance O-2022-03, which repeals the 55 mile an hour speed limit on Shannon Road and Councilwoman Critz seconded. The motion passed unanimously. Ayes: Coffey, Countryman, Critz, Cureton, and Muller. Nays: None.

The ordinance (O-2022-03) is as follows:

STATE OF NORTH CAROLINA
TOWN OF MINERAL SPRINGS

**AN ORDINANCE DECLARING SPEED LIMIT MODIFICATION
CONCURRING WITH THE DEPARTMENT OF TRANSPORTATION
ORDINANCE
O-2022-03**

WHEREAS, N.C. G.S. 20-141 (f) authorizes speed limit modifications based upon engineering and traffic investigation on portions of a State Highway System Street located in the Town of Mineral Springs;

NOW, THEREFORE BE IT ORDAINED by the Town Council of the Town of Mineral Springs, North Carolina, the following:

SECTION 1. **Repeal the Following Speed Limit.**

<u>Speed Limit</u>	<u>Route</u>	<u>Road Description</u>
55	SR 1328	(Shannon Road) from a point 0.25 mile north of SR 1327 (Pleasant Grove Road), the southern city limits of Mineral Springs, northward to a point 0.59 mile north of SR 1327, the northern city limits of Mineral Springs.

SECTION 2. **Effective date.** This ordinance is effective upon adoption of the Department of Transportation of a concurring ordinance and the erection of signs giving notice of the authorized speed limit.

ADOPTED this 13th day of October, 2022. Witness my hand and official seal:

Frederick Becker III, Mayor

Attest:

Vicky A. Brooks, CMC, Town Clerk

Councilman Muller motioned to adopt ordinance 0-2022-04 which enacts the 45 mile an hour speed limit on Shannon Road and Councilman Countryman seconded. The motion passed unanimously as follows: Ayes: Coffey, Countryman, Critz, Cureton, and Muller. Nays: None.

The ordinance (O-2022-04) is as follows:

STATE OF NORTH CAROLINA
TOWN OF MINERAL SPRINGS

**AN ORDINANCE DECLARING SPEED LIMIT MODIFICATION
CONCURRING WITH THE DEPARTMENT OF TRANSPORTATION
ORDINANCE
O-2022-04**

WHEREAS, N.C. G.S. 20-141 (f) authorizes speed limit modifications based upon engineering and traffic investigation on portions of a State Highway System Street located in the Town of Mineral Springs;

NOW, THEREFORE BE IT ORDAINED by the Town Council of the Town of Mineral Springs, North Carolina, the following:

SECTION 1. Enact the Following Speed Limit.

<u>Speed Limit</u>	<u>Route</u>	<u>Road Description</u>
45	SR 1328	SR 1328 (Shannon Road) from a point 0.11 mile north of SR 1327 (Pleasant Grove Road), the southern city limits of Mineral Springs, northward to a point 0.59 mile north of SR 1327, the northern city limits of Mineral Springs.

SECTION 2. Effective date. This ordinance is effective upon adoption of the Department of Transportation of a concurring ordinance and the erection of signs giving notice of the authorized speed limit.

ADOPTED this 13th day of October, 2022. Witness my hand and official seal:

Frederick Becker III, Mayor

Attest:

Vicky A. Brooks, CMC, Town Clerk

9. Proclamation for Domestic Violence Month – Action Item

Councilwoman Critz motioned to adopt the Proclamation for Domestic Violence Awareness being October 2022 and Councilman Muller seconded. The motion passed unanimously. Ayes: Coffey, Countryman, Critz, Cureton, and Muller. Nays: None.

10. Staff Updates

There were no staff updates.

11. Other Business

There was no other business.

12. Adjournment – Action Item

At 8:15 p.m. Councilwoman Coffey motioned to adjourn the meeting and Councilman Muller seconded. The motion passed unanimously. Ayes: Coffey, Countryman, Critz, Cureton, and Muller. Nays: None.

The next regular meeting will be on Thursday, November 10, 2022 at 7:30 p.m. at the Mineral Springs Town Hall.

Respectfully submitted by:

Vicky A. Brooks, CMC, NCCMC, Town Clerk

Frederick Becker III, Mayor

DRAFT

To: Town of Mineral Springs
Rick Becker

From: Vann Harrell 
Tax Administrator

Date: October 13, 2022

Re: Departmental Monthly Report

The Tax Collector's monthly/year to date collections report for the month ending September 30, 2022 is attached for your information and review.

Should you desire additional information, I will provide that at your request.

Attachment

VH/JM

SEPTEMBER 2022
TOWN OF MINERAL SPRINGS
PERCENTAGE REPORT

SEPTEMBER 30, 2022 REGULAR TAX	2022	2021	2020	2019	2018	2017
BEGINNING CHARGE	79,006.36	80,027.69	69,694.82	67,992.78	67,409.94	65,441.40
TAX CHARGE						
PUBLIC UTILITIES CHARGES						
DISCOVERIES						
NON-DISCOVERIES						
RELEASES						
TOTAL CHARGE	79,006.36	80,027.69	69,694.82	67,992.78	67,409.94	65,441.40
BEGINNING COLLECTIONS	3,844.87	79,841.38	69,556.98	67,860.21	67,347.43	65,375.36
COLLECTIONS - TAX	5,373.08	5.86	0.44			
COLLECTIONS - INTEREST		0.14	0.08			
TOTAL COLLECTIONS	9,217.95	79,847.24	69,557.42	67,860.21	67,347.43	65,375.36
BALANCE OUTSTANDING	69,788.41	180.45	137.40	132.57	62.51	66.04
PERCENTAGE OF REGULAR	11.67%	99.77%	99.80%	99.81%	99.91%	99.90%
COLLECTION FEE 1.25 %	67.16	0.08	0.01	-	-	-

SEPTEMBER 2022
TOWN OF MINERAL SPRINGS
PERCENTAGE REPORT

2016	2015	2014	2013
61,553.74	62,157.91	64,338.55	64,894.00
61,553.74	62,157.91	64,338.55	64,894.00
61,487.70	62,135.35	64,313.12	64,873.47
61,487.70	62,135.35	64,313.12	64,873.47
66.04	22.56	25.43	20.53
99.89%	99.96%	99.96%	99.97%
-	-	-	-

Town of Mineral Springs

FINANCE REPORT

September 2022

Prepared for:

The Mineral Springs Town Council

By:

Frederick Becker III
Finance Officer

November 10, 2022

This page has been intentionally left blank.

Cash Flow Report FY2022 YTD - Q3 2022

7/1/2022 through 9/30/2022

10/24/2022

Page 1

Category	7/1/2022- 9/30/2022
INCOME	
Interest Income	642.87
Other Inc	
NC Grant	135,309.37
Zoning	1,195.00
TOTAL Other Inc	136,504.37
Prop Tax 2022	
Receipts 2022	
Tax	3,842.50
TOTAL Receipts 2022	3,842.50
TOTAL Prop Tax 2022	3,842.50
Prop Tax Prior Years	
Prop Tax 2019	
Receipts 2019	
Int	0.87
Tax	3.45
TOTAL Receipts 2019	4.32
TOTAL Prop Tax 2019	4.32
Prop Tax 2020	
Receipts	
Int	0.69
Tax	4.02
TOTAL Receipts	4.71
TOTAL Prop Tax 2020	4.71
Prop Tax 2021	
Receipts 2021	
Int	0.73
Tax	13.88
TOTAL Receipts 2021	14.61
TOTAL Prop Tax 2021	14.61
TOTAL Prop Tax Prior Years	23.64
Sales Tax	
Sales & Use Dist	3,420.18
TOTAL Sales Tax	3,420.18
Veh Tax	
Int 2022	7.50
Tax 2020	-15.73
Tax 2022	721.64
TOTAL Veh Tax	713.41
TOTAL INCOME	145,146.97
EXPENSES	
Attorney	900.00
Capital Outlay	
Furniture	1,351.90
TOTAL Capital Outlay	1,351.90
Community	
Greenway	600.00
Parks & Rec	
Park	1,665.79

Cash Flow Report FY2022 YTD - Q3 2022

7/1/2022 through 9/30/2022

10/24/2022

Page 2

Category	7/1/2022- 9/30/2022
TOTAL Parks & Rec	1,665.79
Special Events	
Misc	100.00
TOTAL Special Events	100.00
TOTAL Community	2,365.79
Emp	
Benefits	
Dental	304.00
Life	243.20
NCLGERS	4,782.45
Vision	56.00
TOTAL Benefits	5,385.65
Bond	550.00
FICA	
Med	517.45
Soc Sec	2,212.58
TOTAL FICA	2,730.03
Payroll	512.12
Work Comp	2,026.78
TOTAL Emp	11,204.58
Office	
Bank	0.00
Clerk	10,209.00
Council	3,600.00
Deputy Clerk	3,827.61
Dues	4,681.00
Equip	131.03
Finance Officer	9,432.00
Ins	4,212.96
Maint	
Materials	161.04
Service	4,482.88
TOTAL Maint	4,643.92
Mayor	1,500.00
Misc	288.22
Records	5,402.44
Supplies	1,029.21
Tel	3,348.36
Util	802.05
TOTAL Office	53,107.80
Planning	
Administration	
Contract	1,445.58
Salaries	8,826.00
TOTAL Administration	10,271.58
Misc	427.00
TOTAL Planning	10,698.58
Street Lighting	206.51
Tax Coll	
Contract	70.91
TOTAL Tax Coll	70.91

Cash Flow Report FY2022 YTD - Q3 2022

7/1/2022 through 9/30/2022

10/24/2022

Page 3

Category	7/1/2022- 9/30/2022
Training	
Staff	225.00
TOTAL Training	225.00
Travel	1,327.87
TOTAL EXPENSES	81,458.94
TRANSFERS	
FROM Check Min Spgs	135,309.37
FROM MM Sav ParkSterling	941,475.02
TO Idle Funds First National	-941,475.02
TO SLFRF Revenues	-135,309.37
TOTAL TRANSFERS	0.00
OVERALL TOTAL	63,688.03

This page has been intentionally left blank.

Account Balances History Report - As of 9/30/2022

(Includes unrealized gains)

Account	6/29/2022 Balance	6/30/2022 Balance	7/31/2022 Balance	8/31/2022 Balance	9/30/2022 Balance
ASSETS					
Cash and Bank Accounts					
Check Min Spgs	118,815.17	118,296.91	79,927.33	60,879.93	107,309.40
Idle Funds First National	0.00	0.00	0.00	0.00	941,659.45
MM Sav ParkSterling	941,271.29	941,309.97	941,347.36	941,475.02	0.00
NCCMT_Cash	2,359.74	2,361.64	2,364.68	2,368.97	2,373.69
SLFRF Revenues	135,309.38	135,337.74	135,396.88	270,783.78	270,928.45
SLFRF Fund	0.00	0.00	0.00	0.00	0.00
TOTAL Cash and Bank Accounts	1,197,755.58	1,197,306.26	1,159,036.25	1,275,507.70	1,322,270.99
Other Assets					
State Revenues Receivable	0.00	64,074.77	60,166.29	56,193.28	0.00
TOTAL Other Assets	0.00	64,074.77	60,166.29	56,193.28	0.00
TOTAL ASSETS	1,197,755.58	1,261,381.03	1,219,202.54	1,331,700.98	1,322,270.99
LIABILITIES					
Other Liabilities					
Accounts Payable	692.76	11,276.25	9,178.72	8,478.18	8,478.18
Restricted Fund Balance	135,309.38	135,309.38	135,309.38	270,618.75	270,618.75
TOTAL Other Liabilities	136,002.14	146,585.63	144,488.10	279,096.93	279,096.93
TOTAL LIABILITIES	136,002.14	146,585.63	144,488.10	279,096.93	279,096.93
OVERALL TOTAL	1,061,753.44	1,114,795.40	1,074,714.44	1,052,604.05	1,043,174.06

Mineral Springs Budget Comparison 2022-23

TOWN OF MINERAL SPRINGS										
BUDGET COMPARISON 2022-23										
Appropriation dept	Budget	Unspent	Spent YTD	% of Budget	July	August	September	October	November	
Advertising	\$ 1,800.00	\$ 1,800.00	\$ -	0.0%	\$ -	\$ -	\$ -			
Attorney	\$ 9,600.00	\$ 8,700.00	\$ 900.00	9.4%	\$ 300.00	\$ 300.00	\$ 300.00			
Audit	\$ 4,730.00	\$ 4,730.00	\$ -	0.0%	\$ -	\$ -	\$ -			
Charities & Agencies	\$ 11,675.00	\$ 11,675.00	\$ -	0.0%	\$ -	\$ -	\$ -			
Community Projects	\$ 22,500.00	\$ 20,134.21	\$ 2,365.79	10.5%	\$ 878.54	\$ 1,472.65	\$ 14.60			
Contingency	\$ 3,000.00	\$ 3,000.00	\$ -	0.0%	\$ -	\$ -	\$ -			
Employee Overhead	\$ 37,400.00	\$ 26,195.42	\$ 11,204.58	30.0%	\$ 5,525.60	\$ 2,887.47	\$ 2,791.51			
Elections	\$ -	\$ -	\$ -	0.0%	\$ -	\$ -	\$ -			
Fire Protection	\$ 12,000.00	\$ 12,000.00	\$ -	0.0%	\$ -	\$ -	\$ -			
Intergovernmental	\$ 15,000.00	\$ 15,000.00	\$ -	0.0%	\$ -	\$ -	\$ -			
Office & Administrative	\$ 162,571.00	\$ 109,463.20	\$ 53,107.80	32.7%	\$ 27,409.91	\$ 14,603.19	\$ 11,094.70			
Planning & Zoning	\$ 47,304.00	\$ 36,605.42	\$ 10,698.58	22.6%	\$ 4,814.58	\$ 2,942.00	\$ 2,942.00			
Street Lighting	\$ 1,400.00	\$ 1,193.49	\$ 206.51	14.8%	\$ -	\$ 102.90	\$ 103.61			
Tax Collection	\$ 1,800.00	\$ 1,729.09	\$ 70.91	3.9%	\$ -	\$ 23.41	\$ 47.50			
Training	\$ 3,000.00	\$ 2,775.00	\$ 225.00	7.5%	\$ 225.00	\$ -	\$ -			
Travel	\$ 4,200.00	\$ 2,872.13	\$ 1,327.87	31.6%	\$ -	\$ 1,327.87	\$ -			
Capital Outlay	\$ 31,325.00	\$ 29,973.10	\$ 1,351.90	4.3%	\$ 1,351.90	\$ -	\$ -			
Totals	\$ 369,305.00	\$ 287,846.06	\$ 81,458.94	22.1%	\$ 40,505.53	\$ 23,659.49	\$ 17,293.92	\$ -	\$ -	\$ -
Off Budget:										
Tax Refunds										
Interfund Transfers										
Total Off Budget:			\$ -		\$ -	\$ -	\$ -	\$ -	\$ -	\$ -

Mineral Springs Monthly Revenue Summary 2022-23

TOWN OF MINERAL SPRINGS											
REVENUE SUMMARY 2022-23											
Source	Budget	Receivable	Rec'd YTD	% of Budget	July	August	September	October	November		
Property Tax - prior	\$ 600.00	\$ 576.36	\$ 23.64	3.9%	\$ -	\$ 11.48	\$ 12.16				
Property Tax - 2022	\$ 80,305.00	\$ 76,462.50	\$ 3,842.50	4.8%	\$ -	\$ 54.73	\$ 3,787.77				
Interest	\$ 600.00	\$ (42.87)	\$ 642.87	107.1%	\$ 99.57	\$ 209.48	\$ 333.82				
Sales Tax - Electric	\$ 208,000.00	\$ 208,000.00	\$ -	0.0%	\$ -	\$ -	\$ -				
Sales Tax - Sales & Use	\$ 33,000.00	\$ 29,579.82	\$ 3,420.18	10.4%	\$ -	\$ -	\$ 3,420.18				
Sales Tax - Other Util.	\$ 22,300.00	\$ 22,300.00	\$ -	0.0%	\$ -	\$ -	\$ -				
Sales Tax - Alc. Bev.	\$ 13,000.00	\$ 13,000.00	\$ -	0.0%	\$ -	\$ -	\$ -				
Vehicle Taxes	\$ 7,400.00	\$ 6,686.59	\$ 713.41	9.6%	\$ -	\$ 713.41	\$ -				
Zoning Fees	\$ 3,500.00	\$ 2,305.00	\$ 1,195.00	34.1%	\$ 325.00	\$ 560.00	\$ 310.00				
Other	\$ 600.00	\$ 600.00	\$ -	0.0%	\$ -	\$ -	\$ -				
Totals	\$ 369,305.00	\$ 359,467.40	\$ 9,837.60	2.7%	\$ 424.57	\$ 1,549.10	\$ 7,863.93	\$ -	\$ -	\$ -	\$ -
SLFRF			\$ 135,309.37								
GRAND TOTAL			\$ 145,146.97		\$ 424.57	\$ 136,858.47	\$ 7,863.93	\$ -	\$ -	\$ -	\$ -
						May	June	June a/r			
Property Tax - prior											
Property Tax - 2022											
Interest											
Sales Tax - Electric											
Sales Tax - Sales & Use											
Sales Tax - Other Util.											
Sales Tax - Alc. Bev.											
Vehicle Taxes											
Zoning Fees											
Other											
Totals	\$ -	\$ -	\$ -	\$ -	\$ -	\$ -	\$ -	\$ -	\$ -	\$ -	\$ -
SLFRF											
GRAND TOTAL	\$ -	\$ -	\$ -	\$ -	\$ -	\$ -	\$ -	\$ -	\$ -	\$ -	\$ -

September 2022 Cash Flow Report FY2022 - Sep 2022

9/1/2022 through 9/30/2022

10/24/2022

Page 1

Category	9/1/2022- 9/30/2022
INCOME	
Interest Income	333.82
Other Inc	
Zoning	310.00
TOTAL Other Inc	310.00
Prop Tax 2022	
Receipts 2022	
Tax	3,787.77
TOTAL Receipts 2022	3,787.77
TOTAL Prop Tax 2022	3,787.77
Prop Tax Prior Years	
Prop Tax 2019	
Receipts 2019	
Int	0.87
Tax	3.45
TOTAL Receipts 2019	4.32
TOTAL Prop Tax 2019	4.32
Prop Tax 2020	
Receipts	
Int	0.54
Tax	3.23
TOTAL Receipts	3.77
TOTAL Prop Tax 2020	3.77
Prop Tax 2021	
Receipts 2021	
Int	0.27
Tax	3.80
TOTAL Receipts 2021	4.07
TOTAL Prop Tax 2021	4.07
TOTAL Prop Tax Prior Years	12.16
Sales Tax	
Sales & Use Dist	3,420.18
TOTAL Sales Tax	3,420.18
TOTAL INCOME	7,863.93
EXPENSES	
Attorney	300.00
Community	
Parks & Rec	
Park	14.60
TOTAL Parks & Rec	14.60
TOTAL Community	14.60
Emp	
Benefits	
Dental	76.00
Life	60.80
NCLGERS	1,594.15
Vision	14.00
TOTAL Benefits	1,744.95
FICA	

September 2022 Cash Flow Report FY2022 - Sep 2022

9/1/2022 through 9/30/2022

10/24/2022

Page 2

Category	9/1/2022- 9/30/2022
Med	166.74
Soc Sec	712.96
TOTAL FICA	879.70
Payroll	166.86
TOTAL Emp	2,791.51
Office	
Clerk	3,403.00
Council	1,200.00
Deputy Clerk	879.61
Finance Officer	3,144.00
Maint	
Materials	53.27
Service	608.00
TOTAL Maint	661.27
Mayor	500.00
Misc	144.11
Supplies	622.72
Tel	267.79
Util	272.20
TOTAL Office	11,094.70
Planning	
Administration	
Salaries	2,942.00
TOTAL Administration	2,942.00
TOTAL Planning	2,942.00
Street Lighting	103.61
Tax Coll	
Contract	47.50
TOTAL Tax Coll	47.50
TOTAL EXPENSES	17,293.92
TRANSFERS	
FROM MM Sav ParkSterling	941,475.02
TO Idle Funds First National	-941,475.02
TOTAL TRANSFERS	0.00
OVERALL TOTAL	-9,429.99

Register Report - Sep 2022

9/1/2022 through 9/30/2022

10/24/2022

Page 1

Date	Num	Description	Memo	Category	Cl	Amount
9/1/2022	EFT	Point And Pay	06-084-007 (FY2022)	Other Inc:Zoning	R	50.00
9/10/2022	EFT	Debit Card (Lowe's)	Marking Paint (FY2022)	Office:Maint:Materials	R	-53.27
9/12/2022	EFT	...Union County	8/2022 (FY2022)	Prop Tax 2022:Receipts 2022:T...	R	3,787.77
			8/2022 (FY2022)	Prop Tax Prior Years:Prop Tax ...	R	3.80
			8/2022 (FY2022)	Prop Tax Prior Years:Prop Tax ...	R	0.27
			8/2022 (FY2022)	Prop Tax Prior Years:Prop Tax ...	R	3.23
			8/2022 (FY2022)	Prop Tax Prior Years:Prop Tax ...	R	0.54
			8/2022 (FY2022)	Prop Tax Prior Years:Prop Tax ...	R	3.45
			8/2022 (FY2022)	Prop Tax Prior Years:Prop Tax ...	R	0.87
			8/2022 (FY2022)	Tax Coll:Contract	R	-47.50
9/12/2022	6448	Clark, Griffin & McCol...	I/N 8056 9/2022 (FY2022)	Attorney	R	-300.00
9/12/2022	6449	Bucket, Mop, And Bro...	I/N BMBC-1023 janitorial 9/2022 (F...	Office:Maint:Service	R	-188.00
9/12/2022	6450	Duke Power	9100 3284 5207 (FY2022)	Street Lighting	R	-103.61
9/12/2022	6451	Union County Water {...	A/N 84361*00 (FY2022)	Office:Util	R	-38.21
9/12/2022	6452	Union County Water {...	A/N 91052*00 (FY2022)	Community:Parks & Rec:Park	R	-14.60
9/12/2022	6453	Taylor & Sons Mowin...	I/N 0033 9/22 regular (FY2022)	Office:Maint:Service	R	-420.00
9/12/2022	EFT	Debit Card (AOL)	AOL Troubleshooting Svc 09/22 (F...	Office:Tel	R	-7.99
9/13/2022	EFT	Point And Pay	06-057-169 (FY2022)	Other Inc:Zoning	R	50.00
9/14/2022	EFT	Debit Card (Dollar Ge...	Batteries (FY2022)	Office:Supplies	R	-25.89
9/15/2022	TXFR	NC Department of Re...	Utility Distributions (FY2021)	[State Revenues Receivable]	R	56,193.28
9/15/2022	EFT	NC Department of Re...	Sales & Use Distribution 7/22 (FY2...	Sales Tax:Sales & Use Dist	R	3,420.18
9/21/2022	EFT	Debit Card (Crystal I...	DUPLICATE Retirement Clock - Ja...	Office:Misc	R	-144.11
9/22/2022	EFT	Point And Pay	6520 (FY2022)	Other Inc:Zoning	R	25.00
9/26/2022	6454	Xerox Corporation	I/N 016980221 (FY2022)	Office:Supplies		-166.36
9/26/2022	6455	Windstream	061348611 (FY2022)	Office:Tel		-259.80
9/26/2022	6456	Forms & Supply, Inc.	I/N 6238206-0 (FY2022)	Office:Supplies	R	-252.09
9/26/2022	6457	...Municipal Insurance ...	09/22 (FY2022)	Emp:Benefits:Life	R	-60.80
			09/22 (FY2022)	Emp:Benefits:Dental	R	-76.00
			09/22 (fy2022)	Emp:Benefits:Vision	R	-14.00
9/26/2022	6458	Duke Power{Office}	9100 3284 4818 (FY2022)	Office:Util	R	-206.30
9/26/2022	6459	Duke Power	9100 3284 5041 (Old School) (FY2...	Office:Util	R	-27.69
9/26/2022	EFT	Debit Card (ebay)	Toner, drum, parts - finance office (...	Office:Supplies	R	-178.38
9/26/2022	EFT	Point And Pay	06-054-017 (FY2022)	Other Inc:Zoning	R	10.00
9/26/2022	EFT	Point And Pay	06-018-098 (FY2022)	Other Inc:Zoning	R	25.00
9/29/2022	EFT	...Paychex	Salary 9/22 (FY2022)	Office:Clerk	R	-3,198.82
			9/22 Janet (FY2022)	Office:Deputy Clerk	R	-228.00
			9/22 (Maurice) (FY2022)	Office:Deputy Clerk	R	-651.61
			Salary 9/22 (FY2022)	Office:Finance Officer	R	-2,955.36
			Salary 9/22 (FY2022)	Office:Mayor	R	-500.00
			Salary 9/22 (FY2022)	Office:Council	R	-1,200.00
			Salary 9/22 (FY2022)	Planning:Administration:Salaries	R	-2,765.48
			FY2022	Emp:FICA:Soc Sec	R	-712.96
			FY2022	Emp:FICA:Med	R	-166.74
9/29/2022	EFT	...NC State Treasurer	09/22 LGERS contribution FY2022	Office:Clerk	R	-204.18
			09/22 LGERS contribution FY2022	Office:Finance Officer	R	-188.64
			09/22 LGERS contribution FY2022	Planning:Administration:Salaries	R	-176.52
			09/22 employer contribution FY2022	Emp:Benefits:NCLGERS	R	-1,594.15
9/30/2022	EFT	Paychex Fees	Fees 9/22 (FY2022)	Emp:Payroll	R	-166.86
9/30/2022	DEP	Deposit	#22004 (FY2022)	Other Inc:Zoning	R	150.00
9/1/2022 - 9/30/2022						46,429.47

Register Report - Sep 2022

9/1/2022 through 9/30/2022

10/24/2022

Page 2

Date	Num	Description	Memo	Category	Cl Amount
<hr/>					
TOTAL INFLOWS					
63,723.39					
<hr/>					
TOTAL OUTFLO...					
-17,293.92					
<hr/>					
NET TOTAL					
46,429.47					

Accounts Rcvble Activity July-Sept 2022

6/30/2022 through 9/30/2022

10/24/2022

Page 1

Date	Description	Memo	Category	Amount
6/30/2022	Union County {NCVTS} 5/22 (FY2021)		Veh Tax:Tax 2021	685.63
	5/22 (FY2021)		Veh Tax:Int 2021	5.00
	5/22 Refunds (FY2021)		Veh Tax:Tax 2021	1.51
6/30/2022	Union County 6/2022 (FY2021)		Prop Tax 2022:Prepayments	0.51
	6/2022 (FY2021)		Prop Tax 2021:Receipts 2021:Tax	98.48
	6/2022 (FY2021)		Prop Tax 2021:Receipts 2021:Int	5.54
	6/2022 (FY2021)		Prop Tax Prior Years:Prop Tax 2...	0.96
	6/2022 (FY2021)		Prop Tax Prior Years:Prop Tax 2...	0.14
6/30/2022	NC Department of Re... Sales & Use Distribution 5/22 (FY2021)		Sales Tax:Sales & Use Dist	3,110.71
6/30/2022	NC Department of Re... Sales & Use Distribution 6/22 ESTIMAT...		Sales Tax:Sales & Use Dist	2,775.00
6/30/2022	NC Department of Re... Electricity 6/22 ESTIMATED (FY2021)		Sales Tax:Electricity	50,350.00
6/30/2022	NC Department of Re... Cable TV 6/22 ESTIMATED (FY2021)		Sales Tax:Cable TV	4,600.00
6/30/2022	NC Department of Re... Telecommunications 6/22 ESTIMATED (...)		Sales Tax:telecommunications	700.00
6/30/2022	NC Department of Re... Nat. Gas Excise 6/22 ESTIMATED (FY2...		Sales Tax:Natural Gas Excise	1,300.00
6/30/2022	Union County {NCVTS} 6/22 (FY2021)		Veh Tax:Tax 2021	737.31
	6/22 (FY2021)		Veh Tax:Int 2021	6.47
	6/22 Refunds (FY2021)		Veh Tax:Tax 2021	2.93
6/30/2022	NC Department of Re... Sales & Use Distribution 6/22 CORREC...		Sales Tax:Sales & Use Dist	451.30
6/30/2022	NC Department of Re... Electricity 6/22 CORRECTION (FY2021)		Sales Tax:Electricity	77.44
6/30/2022	NC Department of Re... Cable TV 6/22 CORRECTION (FY2021)		Sales Tax:Cable TV	248.56
6/30/2022	NC Department of Re... Telecommunications 6/22 CORRECTIO...		Sales Tax:telecommunications	-68.20
6/30/2022	NC Department of Re... Natural Gas Excise 6/22 CORRECTION ...		Sales Tax:Natural Gas Excise	-1,014.52
7/1/2022	Union County {NCVTS} 5/22 NCVTS (FY2021)		[Check Min Spgs]	-692.14
7/11/2022	Union County 06/22 Prop Tax (FY2021)		[Check Min Spgs]	-105.63
7/15/2022	NC Department of Re... Sales & Use Distribution 5/22 (FY2021)		[Check Min Spgs]	-3,110.71
8/1/2022	Union County {NCVTS} 6/22 NCVTS (FY2021)		[Check Min Spgs]	-746.71
8/15/2022	NC Department of Re... Sales & Use Distribution 6/22 (FY2021)		[Check Min Spgs]	-3,226.30
9/15/2022	NC Department of Re... Utility Distributions (FY2021)		[Check Min Spgs]	-56,193.28
6/30/2022 - 9/30/2022				0.00
			TOTAL INFLOWS	65,157.49
			TOTAL OUTFLOWS	-65,157.49
			NET TOTAL	0.00

Accounts Payable Activity July-September 2022

6/30/2022 through 9/30/2022

10/24/2022

Page 1

Date	Description	Memo	Category	Clr Amount
BALANCE 6/29/2022				-692.76
6/30/2022	Union County {NCVTS}	5/22 NCVTS Commission (FY2021)	Tax Coll:Contract	-24.06
6/30/2022	Union County	6/22 Regular Taxes Commission (FY2021)	Tax Coll:Contract	-1.59
6/30/2022	Taylor & Sons Mowing & La...	I/N 0030A Fire Ant Treatment (FY2021)	Office:Maint:Ser...	-792.00
6/30/2022	The Enquirer-Journal	30065439 Budget Hearing Ad (FY2021)	Ads	-39.80
6/30/2022	Union County Water {Office}	A/N 84361*00 (FY2021)	Office:Util	-37.72
6/30/2022	Union County Water {Park}	A/N 91052*00 (FY2021)	Community:Park...	-15.57
6/30/2022	Xerox Corporation	I/N 016528119 (FY2021)	Office:Supplies	-128.39
6/30/2022	Perry, Bundy, Plyler & Long ...	Legal - Donato violation (FY2021)	Attorney	-772.50
6/30/2022	Xerox Corporation	Altalink C8145 (FY2021)	Capital Outlay:E...	-7,785.42
6/30/2022	Ken Newell	Welcome Signs 4/22 - 6/22 (FY2021)	Community:Maint	-675.00
6/30/2022	Union County	6/22 NCVTS Commission (FY2021)	Tax Coll:Contract	-25.54
6/30/2022	Duke Power{Office}	9100 3284 4818 (FY2021)	Office:Util	-259.29
6/30/2022	Duke Power	9100 3284 5041 (Old School) (FY2021)	Office:Util	-26.61
7/1/2022	Union County {NCVTS}	5/22 NCVTS Commission (FY2021)	[Check Min Spgs]	24.06
7/11/2022	Taylor & Sons Mowing & La...	I/N 0030A Fire Ant Treatment (FY2021)	[Check Min Spgs]	792.00
7/11/2022	The Enquirer-Journal	30065439 Budget Hearing Ad (FY2021)	[Check Min Spgs]	39.80
7/11/2022	Union County Water {Office}	A/N 84361*00 (FY2021)	[Check Min Spgs]	37.72
7/11/2022	Union County Water {Park}	A/N 91052*00 (FY2021)	[Check Min Spgs]	15.57
7/11/2022	Union County	6/22 Regular Taxes Commission (FY2021)	[Check Min Spgs]	1.59
7/14/2022	Xerox Corporation	I/N 016528119 (FY2021)	[Check Min Spgs]	128.39
7/14/2022	Perry, Bundy, Plyler & Long ...	Legal - Donato violation (FY2021)	[Check Min Spgs]	772.50
7/25/2022	Duke Power	9100 3284 5041 (Old School) (FY2021)	[Check Min Spgs]	26.61
7/25/2022	Duke Power{Office}	9100 3284 4818 (FY2021)	[Check Min Spgs]	259.29
8/1/2022	Union County	6/22 NCVTS Commission (FY2021)	[Check Min Spgs]	25.54
8/2/2022	Ken Newell	Welcome Signs 4/22 - 6/22 (FY2021)	[Check Min Spgs]	675.00
6/30/2022 - 9/30/2022				-7,785.42
BALANCE 9/30/2022				-8,478.18
TOTAL INFLOWS				2,798.07
TOTAL OUTFLOWS				-10,583.49
NET TOTAL				-7,785.42

This page has been intentionally left blank.

September 2022

- Revenue Details
- Inter-bank Transfers

This page has been intentionally left blank.

NC Sales & Use Distribution

July 2022 Collections

Summary

MUNICIPALITY	ARTICLE 39	ARTICLE 40	ARTICLE 42	ARTICLE 43	ARTICLE 44	ART 44 *524	ARTICLE 45	ARTICLE 46	CITY HH	TOTAL
UNION										
(AD VALOREM)	3,000,659.62	1,931,183.62	1,579,528.88	-	6.52	404,819.62	-	-	(488,625.11)	6,427,573.15
FAIRVIEW	1,631.95	1,050.30	859.05	-	-	220.17	-	-	1,070.47	4,831.94
HEMBY BRIDGE	-	-	-	-	-	-	-	-	-	-
INDIAN TRAIL	136,029.07	87,546.46	71,604.87	-	0.30	18,351.71	-	-	89,226.97	402,759.38
LAKE PARK	9,758.37	6,280.35	5,136.74	-	0.02	1,316.50	-	-	6,400.92	28,892.90
MARSHVILLE	15,667.40	10,083.32	8,247.22	-	0.03	2,113.69	-	-	10,276.88	46,388.54
MARVIN	12,400.13	7,980.55	6,527.35	-	0.03	1,672.90	-	-	8,133.75	36,714.71
MINERAL SPRINGS	1,155.14	743.43	608.06	-	-	156.84	-	-	757.71	3,420.18
MINT HILL *	54.69	35.19	28.79	-	-	7.38	-	-	35.87	161.92
MONROE	321,214.42	206,729.22	169,085.31	-	0.70	43,335.10	-	-	210,697.52	951,062.27
STALLINGS *	60,861.60	39,169.69	32,037.17	-	0.13	8,210.85	-	-	39,921.58	180,201.02
UNIONVILLE	2,202.78	1,417.68	1,159.53	-	-	297.18	-	-	1,444.90	6,522.07
WAXHAW	152,606.65	98,215.56	80,331.21	-	0.33	20,588.19	-	-	100,100.87	451,842.81
WEDDINGTON *	20,353.87	13,099.47	10,714.15	-	0.04	2,745.94	-	-	13,350.92	60,264.39
WESLEY CHAPEL	2,616.66	1,684.05	1,377.40	-	0.01	353.01	-	-	1,716.37	7,747.50
WINGATE	8,370.25	5,386.98	4,406.05	-	0.02	1,129.23	-	-	5,490.38	24,782.91
TOTAL	3,745,582.60	2,410,605.87	1,971,651.78	-	8.13	505,317.31	-	-	-	8,633,165.69

Invoice Date	Invoice Number	Description	Invoice Amount
09/01/2022	2302 TAXES	TAX/FEE/INT-AUG 2022	\$3,752.43

Vendor No.	Vendor Name	Check No.	Check Date	Check Amount
10870	TOWN OF MINERAL SPRINGS	00077171	09/12/2022	3,752.43



County of Union
 500 North Main Street
 Monroe, North Carolina 28112

Vendor Number Check Date Check Number
 10870 09/12/2022 00077171

"This disbursement has been approved as required by the Local Government Budget and Fiscal Control Act."

\$3,752.43

Pay Three Thousand Seven Hundred Fifty Two Dollars and 43 cents *****

To The TOWN OF MINERAL SPRINGS
 Order Of PO BOX 600
 MINERAL SPRINGS NC 28108

**EFT COPY
 NON-NEGOTIABLE**

AP



County of Union
 500 North Main Street
 Monroe, North Carolina 28112

10870
 00077171

ADDRESS SERVICE REQUESTED

TOWN OF MINERAL SPRINGS
 PO BOX 600
 MINERAL SPRINGS NC 28108

Jurisdiction Collection by Year
Union County
Date Distributed: 8/1/2022 to 8/31/2022

990 - TOWN OF MINERAL SPRINGS

Year	Taxes, Assessments and Misc. Charges	Late List	Interest	Total Collected	Commission	Net of Commission
2019	3.45	0.00	0.87	4.32	0.05	4.27
2020	2.94	0.29	0.54	3.77	0.05	3.72
2021	3.54	0.26	0.27	4.07	0.05	4.02
2022	3,780.88	6.89	0.00	3,787.77	47.35	3,740.42
Total:	3,790.81	7.44	1.68	3,799.93	47.50	3,752.43
Grand Total:	3,790.81	7.44	1.68	3,799.93	47.50	3,752.43

NC Utility Sales Tax Distribution - 6/30/2022

Prefix	City/County	Sales Tax on Piped Natural Gas	Sales Tax on Electricity	Sales Tax on Telecommunication Services	Sales Tax on Video Programming	Total Distribution
County of	Union	\$ -	\$ -	\$ -	\$ 113,144.23	\$ 113,144.23
Town of	Fairview	\$ 55.97	\$ 24,105.20	\$ 3,622.75	\$ 1,674.46	\$ 29,458.38
Town of	Hemby Bridge	\$ 336.00	\$ 9,084.72	\$ 1,691.87	\$ 3,282.31	\$ 14,394.90
Town of	Indian Trail	\$ 32,649.90	\$ 259,008.88	\$ 11,160.51	\$ 69,469.57	\$ 372,288.86
Town of	Lake Park	\$ 2,620.49	\$ 18,979.58	\$ 216.34	\$ 3,933.28	\$ 25,749.69
Town of	Marshville	\$ -	\$ 38,306.51	\$ 2,810.86	\$ 2,627.77	\$ 43,745.14
Town of	Marvin	\$ 6,086.76	\$ 37,897.78	\$ 6,664.14	\$ 14,141.41	\$ 64,790.09
Town of	Mineral Springs	\$ 285.48	\$ 50,427.44	\$ 631.80	\$ 4,848.56	\$ 56,193.28
City of	Monroe	\$ 72,182.78	\$ 662,887.48	\$ 41,745.44	\$ 47,188.81	\$ 824,004.51
Town of	Stallings	\$ 15,420.04	\$ 132,048.55	\$ 1,061.68	\$ 38,665.06	\$ 187,195.33
Town of	Unionville	\$ 44.51	\$ 37,078.60	\$ 6,962.64	\$ 6,052.71	\$ 50,138.46
Town of	Waxhaw	\$ 14,207.87	\$ 134,405.73	\$ 8,109.27	\$ 63,393.27	\$ 220,116.14
Town of	Weddington	\$ 7,881.30	\$ 73,434.51	\$ 881.40	\$ 26,080.39	\$ 108,277.60
Village of	Wesley Chapel	\$ 5,050.62	\$ 43,948.19	\$ 1,087.73	\$ 21,095.26	\$ 71,181.80
Town of	Wingate	\$ -	\$ 24,428.89	\$ 2,202.29	\$ 4,898.12	\$ 31,529.30

Accrued to FY 2021-22



67-98/532

11642586

CASHIER'S CHECK

PAY TO THE ORDER OF TOWN OF MINERAL SPRINGS

DATE 09/16/2022

\$941,475.02

\$ 941,475.02 DOLLARS

NOTICE TO THE CUSTOMER: AS A CONDITION TO THIS INSTITUTION'S ISSUANCE OF THIS CHECK, PURCHASER AGREES TO PROVIDE DECLARATION OF LOSS PRIOR TO THE REFUND OR REPLACEMENT OF THIS CHECK IN THE EVENT IT IS LOST, MISPLACED, OR STOLEN. REFUNDS AND REPLACEMENTS CANNOT BE MADE FOR 90 DAYS AFTER ISSUANCE OF ORIGINAL CHECK.



Handwritten signature and AUTHORIZED SIGNATURE

REMITTER: Town of Mineral Springs

11642586 063114030 2200830098



CUSTOMER COPY

67-98/532

11642586

CASHIER'S CHECK

PAY TO THE ORDER OF TOWN OF MINERAL SPRINGS

DATE 09/16/2022

\$941,475.02

\$ 941,475.02 DOLLARS

NOTICE TO THE CUSTOMER: AS A CONDITION TO THIS INSTITUTION'S ISSUANCE OF THIS CHECK, PURCHASER AGREES TO PROVIDE DECLARATION OF LOSS PRIOR TO THE REFUND OR REPLACEMENT OF THIS CHECK IN THE EVENT IT IS LOST, MISPLACED, OR STOLEN. REFUNDS AND REPLACEMENTS CANNOT BE MADE FOR 90 DAYS AFTER ISSUANCE OF ORIGINAL CHECK.

REMITTER Town of Mineral Springs

NON-NEGOTIABLE

AUTHORIZED SIGNATURE

COPY

COPY



MONROE

Date September 16, 2022
Time 1:38 PM
Account XXXXXX3996
DDA Withdrawal \$941,475.02

Br# 508 Tir# 7533 Seq# 25

Two easy ways to update your contact info:
Online Banking at SouthStateBank.com
Call us at (800) 277-2175
Member FDIC



First National Bank

Redefining Convenience in Banking

MONROE MAIN
2593 WEST ROOSEVELT BLVD
MONROE, NC 0281100000

Processing Date: 09/16/2022 14:42:50 #100
Calendar Date: 09/16/2022 01

Deposit \$941,475.02
Checking/MHA XXXXXX2805

Deposits of checks not drawn on
First National Bank may not be available
for immediate withdrawal

Thank you for banking with us.
1-800-555-5455 / fnb-online.com



Town of Mineral Springs
Town Clerk / Zoning Administrator
Vicky Brooks
P O Box 600
Mineral Springs, NC 28108
704-289-5331
704-243-1705 FAX
msvickybrooks@aol.com
www.mineralspringsnc.com

MEMO

To: Town Council
From: Vicky Brooks
Date: November 3, 2022
Re: Agenda Item 4 – Consideration of Approving the Lighting Plan for God’s Temple of Zion’s Soccer Field

In accordance with Article 5 – Section 5.6.5.9 of the Mineral Springs Development Ordinance, a zoning permit application from God’s Temple of Zion is attached for approval by the council.

5.6.5.9 AUTHORIZATION FOR INSTALLATION OF PUBLIC AREA AND ROADWAY LIGHTING

Installation of any new public area and roadway lighting fixtures other than for traffic control shall be specifically approved by the Town Council.

God’s Temple of Zion received approval of a Special Use Permit by the Board of Adjustment in May of 2021 for a “Recreation Facilities, public outdoor (excluding parks and playgrounds)” use on their property located at 5902 McNeely Road.

God’s Temple of Zion is now proposing the installation of lighting around the soccer field.

Town of Mineral Springs

3506 S. Potter Road ~ P.O. Box 600 ~ Mineral Springs, NC 28108
704-243-0505 (office) ~ 704-289-5331 (mobile) ~ 704-243-1705 (fax)
Office Hours: 10:00 a.m. to 2:00 p.m. Monday, Tuesday, & Thursday

NON-RESIDENTIAL LIGHTING ZONING PERMIT APPLICATION

Permit # L-22-01 Date of Application: 10/13/2022
Applicant's Name: God's Temple of Zion
Applicant's Mailing Address: 5902 McNeely Road Mineral Springs NC
(P.O. Box 236 Waxhaw)
Applicant's Email Address: faithandfaith@gmail.com
Applicant's Phone Number: (704) 907-9894
Property Location: 5902 McNeely Rd, Mineral Springs NC
Tax Parcel Number: 06-060-00716
Subdivision Name (if any): N/A 16
Existing Zoning: RR 16
Type of Illuminated Devices, Fixtures, Lamps, Supports, Reflectors or Other Devices:
see attachments 16
Yard Location of Lighting: surrounding soccer field - see plot plan

Comments:

Permit Fee: Attach Check Made Payable to Town of Mineral Springs in Amount of \$25. Send application to P.O. Box 600, Mineral Springs, N.C. 28108.

Attach The Following: Two (2) copies of a sealed survey which shows: (a) the shape, dimensions and location of the lot to be built upon; (b) the shape, dimensions, use and location of existing structures on the lot; (c) the shape, dimensions, and location of the accessory or agricultural structure(s) to be placed upon the lot; (d) all setback lines on the lot once the proposed accessory building is completed; and (e) any other information that may be needed to insure that the proposed accessory structure(s) will be in compliance with all applicable provisions of the Mineral Springs Development Ordinance.

I hereby certify that all the information provided for this application and all attachments is true and correct to the best of my knowledge. I further certify that I am familiar with all the requirements of the Mineral Springs Development Ordinance concerning this proposed use. Any violation of the Mineral Springs Development Ordinance will be grounds for revoking this permit and any subsequent permit issued the Town of Mineral Springs.

APPLICANT SIGNATURE  DATE 10/11/22

FOR OFFICE USE ONLY

THIS PERMIT IS: APPROVED _____ DISAPPROVED _____

ZONING ADMINISTRATOR _____ DATE _____

ISOFOOTCANDLE CURVES

FIXTURE: LED130, FLOODLIGHT
 MOUNTING HEIGHT: 25 FT
 LIGHT SOURCE: LED'S, 4000K, 70 CRI

BEAM SPREAD: 6X6 WIDE ANGLE
 ANGLE LUMENS: 17098
 AIMING ANGLE: 45 DEGREES

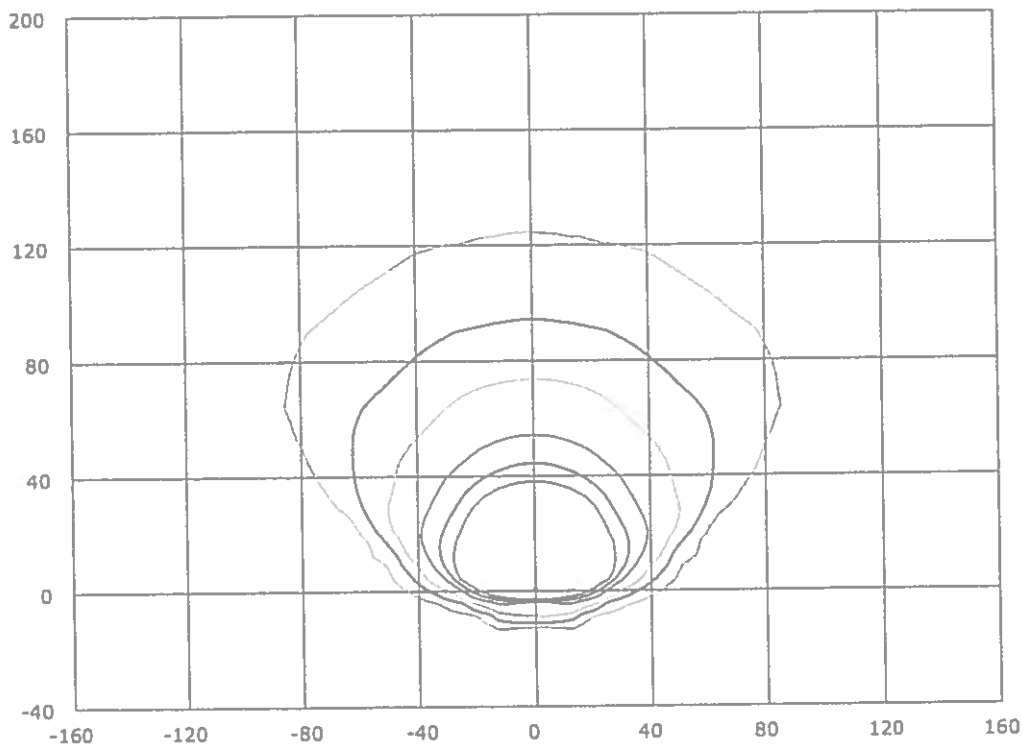

LEGEND (OUTER TO INNER): 0.100 , 0.250 , 0.500 , 1.00 , 1.50 , 2.00



3				
2				
1				
0	10/14/20	MITCHELL	SIMPSONS	GAMMAN
REVISED	BY	CHK'D	APPR.	

130W LED FLOODLIGHT, 4000K
 25FT MOUNTING HEIGHT IES FILE

DEC	DEM	DEP	DEF
X	X	X	X

30.08-316A

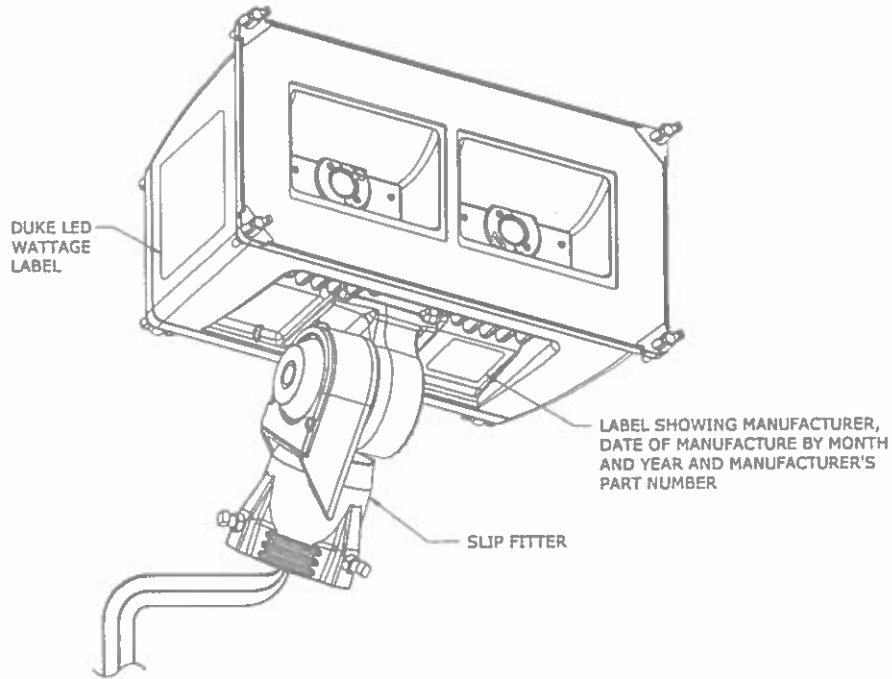
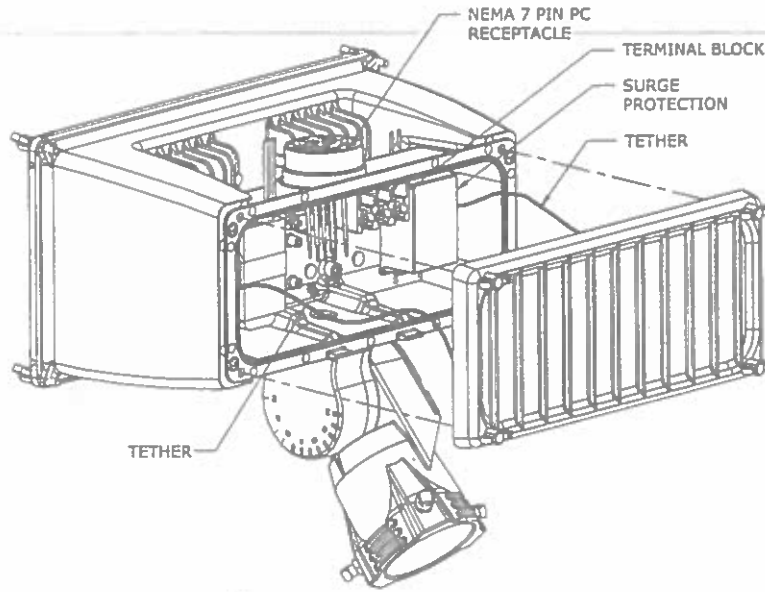

NOTES:

1. GROUND TERMINAL (GREEN WIRE) **MUST** BE CONNECTED TO THE DRIVEN GROUND AND/OR THE SYSTEM NEUTRAL ON ALL LED LUMINAIRES, INCLUDING TWO WIRE 120V APPLICATIONS ON EXISTING POLES.
2. SEE DWGS. 30.07-150A AND 30.07-150B FOR WIRING TO SOURCE CONNECTIONS AND GROUNDING DETAILS.
3. THE DEFAULT AIMING ANGLE IS 45 DEGREES DOWNWARD. USE MARKINGS ON ARM FOR ADJUSTMENT.



3				
2				
1				
0	10/14/20	MITCHELL	SIMPSON	BLOCKER
REVISED	BY	CHK'D	APPR.	

130W LED FLOODLIGHT (SLIP-FITTER)
 FIXTURE COVER PAGE

DEC	DEM	SEP	DEF
X	X	X	X

30.08-304

Outdoor Lighting Solutions
Floodlight LED



Subject to variance by manufacturer. Contact us for region specific details.

The LED Floodlight is perfect for illuminating a dark driveway, parking lot or building exterior. This directional fixture is an excellent choice to help enhance security in any outdoor space.

LED (Light Emitting Diode)	130 260 watts
Mounting height	35'
Colors	Black Bronze Gray
Poles	Style A Wood

For additional information, visit us at duke-energy.com/OutdoorLighting or call us toll free: **800.653.5307**



BUILDING A SMARTER ENERGY FUTURE™

Outdoor Lighting

Floodlight LED

Light source: LED (*white*)

Wattage: 130 | 260

Lumens: 15,000 | 30,000

Light pattern: Directional

Color temperature: 4,000K

Warm-up and restrike time: Instant on (*no warm-up or restrike time*)

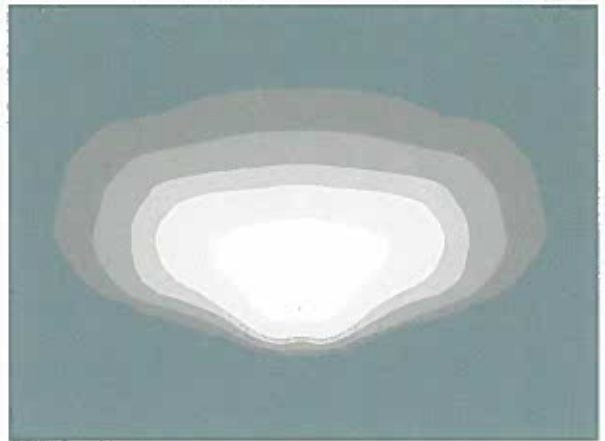

light distribution pattern

Poles available:

Type	Mounting height	Color
Aluminum	35'	Black Bronze Gray
Wood	35'	Standard

Features

Little or no upfront capital cost

Design services by lighting professionals included

Maintenance included

Electricity included

Warranty included

One low monthly cost on your electric bill

Turnkey operation

Backed by over 100 years of experience

Benefits

Frees up capital for other projects

Meets industry standards and lighting ordinances

Eliminates high and unexpected repair bills

Less expensive than metered service

Worry-free

Convenience and savings for you

Provides hassle-free installation and service

A name you can trust today ... and tomorrow

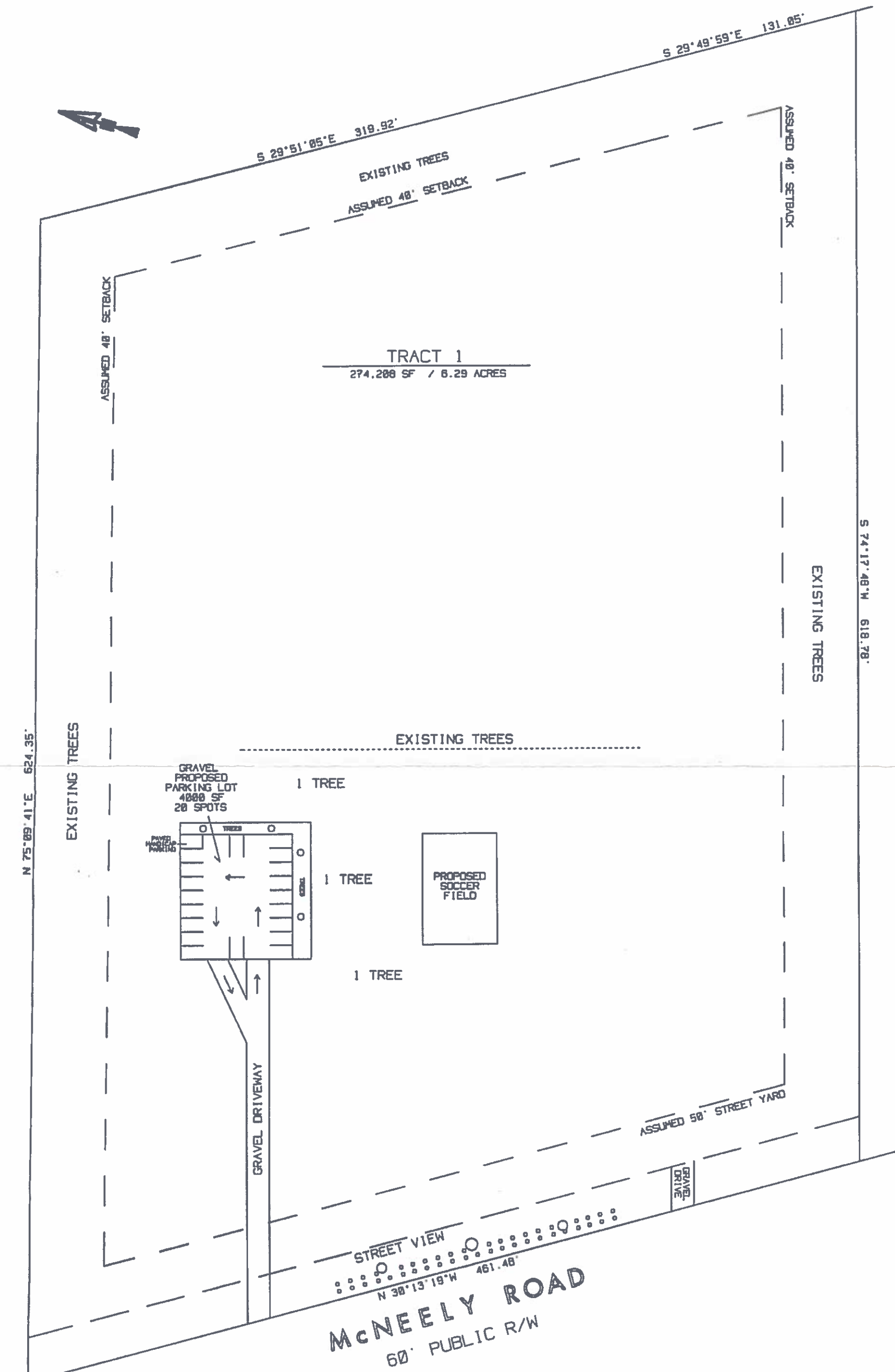

TRACT 1
274,200 SF / 6.29 ACRES



SOCCER FIELD

PLOT PLAN
OF
5828 McNEELY ROAD
TRACT 1, THE LANDS OF JAMES ANDREW BROOME
TOWN OF MINERAL SPRINGS, UNION COUNTY, N.C.
MAP RECORDED IN CABINET L
AT FILE 687
REVISED: 06/21/21
DRAWN BY CLJ

MEMO

To: Mineral Springs Town Council
From: Rick Becker
Date: November 2, 2022
**Subject: Grant Request: Social-Emotional Readiness Program,
D. Coffey Foundation for Athletics and Education**

In August of 2021, Mr. John Tillman got in touch with me about putting together a program in Mineral Springs that would provide social-emotional support and academic remediation to children in the community who had experienced interruptions to their educational path due to the COVID-19 pandemic. Mr. Tillman grew up in Waxhaw and graduated from Parkwood High School in 1984. He has been dedicated to the education of and support for Union County children, including time as a track and field coach at Parkwood High School and involvement with area education non-profits. Mr. Tillman suggested that the program could be funded with grant money the town would be receiving through the American Rescue Plan Act of 2021 (“ARPA”). ARPA funding was being made available to every local and tribal government in the country, and over the previous several months I had attended numerous meetings and webinars with county, municipal, and state officials in an effort to educate myself on how these funds could be utilized. To be honest, the Act had been passed and signed into law so quickly that most of us in the world of local government had no idea what our next steps would be.

The ARPA was first proposed in Congress on January 14, 2021. It proceeded very quickly through both chambers, achieving final passage on March 10, 2021, and was signed into law the next day. Total ARPA appropriations amounted to \$1.9 trillion, with \$350 billion in direct disbursements to state, local, and tribal governments. Out of the latter funding stream, the town of Mineral Springs was awarded \$270,618.75 based on a federal formula that took into account both the town’s population and the dollar amount of the town’s FY2019-20 budget. Mineral Springs received its first CLSFRF direct deposit of \$135,309.38 on August 6, 2021.

In August 2021, we were operating under the so-called “Interim Final Rule” issued by the US Treasury Department in May of 2021. The Rule had specified a very limited number of ways that local governments were authorized to use Coronavirus State and Local Fiscal Recovery Fund (“CSLFRF”) revenues, and many small units of government like ours did not undertake such programs and services and were concerned that we would not be able to use the CSLFRF revenues and would have to forfeit them. One promising solution that was discussed among the parties was partnering with county departments or non-profit agencies that *did* undertake the sort of programs and services for which CSLFRF revenues were authorized. Mr. Tillman’s suggestion would do exactly that: use some of the town’s CSLFRF revenues to fund a grant to a non-profit that could deliver an eligible program.

Early in 2022, Mr. Tillman brought Dr. Delice Coffey into the discussions. Dr. Coffey was born and raised right here in the Western Union neighborhood of Mineral Springs and had been operating the D. Coffey Foundation for Athletics and Education (the foundation’s name has changed several times along the way) in Durham, NC for several decades providing counseling, psychological services, and various programs serving school-age children. I suggested that Mr. Tillman and Dr. Coffey draw up a grant proposal to present to the Mineral Springs town council. Ultimately, Mr. Tillman and Dr. Coffey

designed an after-school program that would meet in Mineral Springs two hours per day, three days per week for six weeks of the second semester of the Union County Public Schools (UCPS) school year in the winter/spring of 2023, and again for six weeks of the first semester of the UCPS school year in the fall of 2023.

The proposed program is called “Social-Emotional Readiness” and is designed to provide both social-skills remediation and academic enrichment and support for Mineral Springs students in grades K-5 who have suffered setbacks in their educational process due to disruptions caused by COVID-19. Loss of in-person school for a year or more negatively impacted millions of children nationwide and these negative effects have been well-documented. The program is described in greater detail in “Appendix A” of the proposed Grant Agreement that is attached.

As Dr. Coffey and Mr. Tillman were working on their proposal, the US Treasury amended the Interim Final Rule in a way that was advantageous to small municipalities. The Final Rule, published on January 6, 2022, allowed local governments to utilize the first \$10 million of any CSLFRF revenues for virtually any normal government expenditure rather than being limited to the very narrow set of authorized uses that had been set forth in the Interim Final Rule. As you recall, Council took the first step toward freeing up the town’s CSLFRF revenues through a grant project ordinance that authorized the town to use CSLFRF revenues to reimburse itself for prior salary expenditures. This process put the Social-Emotional Readiness proposal in a new perspective: while under the interim final rule, such a program would have been one of the *only* ways the town could have spent its CSLFRF revenues, it was now no longer necessary for the town to do so. Of course, the town is still free to fund such a program – especially since it still represents one of the original intended uses of CSLFRF revenues under ARPA - and I suggested that Dr. Coffey and Mr. Tillman move forward with their project and make a presentation to Council along with a grant funding request.

The total budget for the Social-Emotional Readiness program is \$56,194. This amount represents 20.8% of the town’s ARPA/CLSFRF revenues. The program will utilize the so-called “PurposeFull People” curriculum developed by CharacterStrong for children in grades Kindergarten through 5th grade and will be supplemented with additional academic instruction and tutoring designed by Dr. Coffey. The teaching staff will consist of area college students planning careers in teaching, mostly from Wingate University. The program goal is to enroll fifty Mineral Springs children per semester, and the first semester is scheduled to begin in the first week of January 2023 as children are returning to school from the Christmas break.

In addition to the draft Grant Agreement for Council’s consideration, I am attaching some background information on Dr. Coffey and the D. Coffey Foundation for Athletics and Education, the first two pages of a 2005 IRS Form 990 filed by CRA Clinical Services (before Dr. Coffey changed the name of the non-profit), an IRS Determination Letter dated February 17, 2013 confirming the Foundation’s 501(c)(3) status, the D. Coffey Foundation for Athletics and Education’s entry on non-profit evaluation site GuideStar, a confirmation from the IRS that the Foundation is still current with its required Form 990-N filings as of 2021, and a LinkedIn profile for Mr. Tillman.

Dr. Coffey and Mr. Tillman will be attending the November 10, 2022 Regular Town Council Meeting to make their presentation. If Council wishes to fund this program, it should either approve the attached Agreement or propose changes to the agreement and approve a modified agreement. If Council approves this grant funding to the D. Coffey Foundation for Athletics and Education, it will also need to adopt O-2022-05 (modified if necessary), the Project Ordinance which authorizes funding for the Social-Emotional Readiness program.

About

DR. DELICE COFFEY



welcome

I am Dr. Delice Coffey, and I specialize in sport and clinical psychology. I am a native of Waxhaw, North Carolina, and a successful business owner who continues to improve the world around me through my work and dedication. I have spent many years of education and business preparation to develop Living Well Sport & Life and the D. Coffey Foundation for Athletics and Education. I am dedicated to improving overall well-being both mentally and physically by working with the athlete as a whole person. I have created a system to empower individuals educationally, mentally, and physically to be the best version of themselves so that they can soar to the top in sport and life.

I have worked as the team Psychologist for Union County Xtreme AAU basketball team, Hillside High School basketball team, and Hillside High School football team. I volunteer a great deal of my time to the D. Coffey Foundation for Athletics & Education and with the WNBA and Jr. NBA Her Time to Play program.

Education Background

I received my Bachelor of Arts in Psychology and my Master of Arts (with honors) in Clinical Psychology from North Carolina Central University. I received a doctoral degree (with honors) in Sport and Performance Psychology from the University of Western States and a doctoral degree from a non-APA Clinical Psychology program.

I earned a certification in Reality Therapy from the Institute for Reality Therapy under Dr. William Glasser's tutelage – the creator and founder of Reality Therapy. I have worked as a graduate assistant at my Alma Mater in Advanced General Psychology and an adjunct professor in General Psychology. I am a Licensed Psychological Associate and a Certified Mental Game Coach Professional. I also hold a certification in sport-fitness psychology, behavioral therapy, and cognitive therapy. My psychology background, certifications, coupled with my sport-fitness expertise, makes me uniquely qualified to teach sport performance skills to athletes on all levels successfully.

While completing my studies and performing research, I became a member of the Psi Chi Honor Society and was recognized as one of the Outstanding Young Women of America. I was awarded recognition in the Who's Who Among Students in American Universities and Colleges, and I worked as a research associate at Duke University Medical Center.



Form 990

Return of Organization Exempt From Income Tax
Under section 501(c), 527, or 4947(a)(1) of the Internal Revenue Code (except black lung benefit trust or private foundation)

OMB No. 1545-0047

2005

Department of the Treasury Internal Revenue Service

The organization may have to use a copy of this return to satisfy state reporting requirements
For the 2005 calendar year, or tax year beginning 2005, and ending 20

- Check if applicable: Address change, Name change, Initial return, Final return, Amended return, Application pending

Organization information: CRA CLINICAL SERVICES, 1804 MLK JR PKY STE 210, DURHAM, NC 27707. Employer ID: 56-2220734. Telephone: (919) 489-2254.

Section 501(c)(3) organizations and 4947(a)(1) nonexempt charitable trusts must attach a completed Schedule A (Form 990 or 990-EZ).

H and I are not applicable to section 527 organizations

- H(a) Is this a group return for affiliates? Yes No
H(b) If "Yes," enter number of affiliates
H(c) Are all affiliates included? Yes No
H(d) Is this a separate return filed by an organization covered by a group ruling? Yes No

G Website:

J Organization type (check only one) [X] 501(c) (3) (insert no) [] 4947(a)(1) or [] 527

K Check here [] if the organization's gross receipts are normally not more than \$25,000. The organization need not file a return with the IRS, but if the organization chooses to file a return, be sure to file a complete return. Some states require a complete return.

L Gross receipts: Add lines 8b, 8b, 9b, and 10b to line 12 228,704

I Group Exemption Number
M Check [X] if the organization is not required to attach Sch. B (Form 990, 990-EZ, or 990-PF)

Table with 21 rows: Revenue, Expenses, and Changes in Net Assets or Fund Balances. Includes sub-rows for public support, program service revenue, membership dues, interest, dividends, gross rents, net rental income, other investment income, gross amount from sales of assets, special events, gross sales of inventory, other revenue, total revenue, program services, management and general, fundraising, payments to affiliates, total expenses, excess or deficit, net assets at beginning/end of year.

RECEIVED MAY 15 2006 EP/EO - CSPP

POSTMARK RECEIVED

MAY 15 '06 MAY 15 '06

CINCINNATI SERVICE CENTER

SCANNED JUL 03 2006

Statement of Functional Expenses All organizations must complete column (A). Columns (B), (C), and (D) are required for section 501(c)(3) and (4) organizations and section 4947(a)(1) nonexempt charitable trusts but optional for others. (See the instructions.)

Do not include amounts reported on line 6b, 8b, 9b, 10b, or 16 of Part I.		(A) Total	(B) Program services	(C) Management and general	(D) Fundraising
22	Grants and allocations (attach schedule) (cash \$ _____ noncash \$ _____) If this amount includes foreign grants, check here <input type="checkbox"/>	22			
23	Specific assistance to individuals (attach schedule)	23			
24	Benefits paid to or for members (attach schedule)	24			
25	Compensation of officers, directors, etc.	25	40,000	40,000	
26	Other salaries and wages	26	44,155	44,155	
27	Pension plan contributions	27			
28	Other employee benefits	28	4,709	4,709	
29	Payroll taxes	29			
30	Professional fundraising fees	30			
31	Accounting fees	31			
32	Legal fees	32			
33	Supplies	33			
34	Telephone	34	8,278	8,278	
35	Postage and shipping	35	203	203	
36	Occupancy	36	22,709	22,709	
37	Equipment rental and maintenance	37			
38	Printing and publications	38			
39	Travel	39	149	149	
40	Conferences, conventions, and meetings	40			
41	Interest	41			
42	Depreciation, depletion, etc (attach schedule)	42			
43	Other expenses not covered above (itemize).				
a	OTHER	43a	91,092	91,092	
b	TRAINING	43b	88	88	
c	PROFESSIONAL FEES	43c			
d		43d			
e		43e			
f		43f			
g		43g			
44	Total functional expenses. Add lines 22 through 43 (Organizations completing columns (B)-(D), carry these totals to lines 13-15)	44	211,383	211,383	

Joint Costs. Check if you are following SOP 98-2.

Are any joint costs from a combined educational campaign and fundraising solicitation reported in (B) Program services? Yes No
 If "Yes," enter (i) the aggregate amount of these joint costs \$ _____, (ii) the amount allocated to Program services \$ _____,
 (iii) the amount allocated to Management and general \$ _____; and (iv) the amount allocated to Fundraising \$ _____

INTERNAL REVENUE SERVICE
P. O. BOX 2508
CINCINNATI, OH 45201

DEPARTMENT OF THE TREASURY

Date:

FEB 17 2013

CRA OF WAXHAW INC
1804 MLK JR PKY STE 210
DURHAM, NC 27707

Employer Identification Number:
56-2220734
DLN:
17053226361012
Contact Person:
JASON T SAMMONS ID# 31616
Contact Telephone Number:
(877) 829-5500
Accounting Period Ending:
December 31
Public Charity Status:
170(b)(1)(A)(vi)
Form 990 Required:
Yes
Effective Date of Exemption:
August 9, 2012
Contribution Deductibility:
Yes
Addendum Applies:
Yes

Dear Applicant:

We are pleased to inform you that upon review of your application for tax exempt status we have determined that you are exempt from Federal income tax under section 501(c)(3) of the Internal Revenue Code. Contributions to you are deductible under section 170 of the Code. You are also qualified to receive tax deductible bequests, devises, transfers or gifts under section 2055, 2106 or 2522 of the Code. Because this letter could help resolve any questions regarding your exempt status, you should keep it in your permanent records.

Organizations exempt under section 501(c)(3) of the Code are further classified as either public charities or private foundations. We determined that you are a public charity under the Code section(s) listed in the heading of this letter.

Please see enclosed Publication 4221-PC, Compliance Guide for 501(c)(3) Public Charities, for some helpful information about your responsibilities as an exempt organization.

Letter 947 (DO/CG)

CRA OF WAXHAW INC

Sincerely,

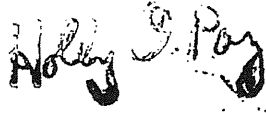
A handwritten signature in black ink that reads "Holly O. Paz". The signature is written in a cursive style with a large initial "H".

Holly O. Paz
Director, Exempt Organizations
Rulings and Agreements

Enclosure: Publication 4221-PC

The D Coffey Foundation for Athletics & Education

Durham, NC | drdcoffey.com/foundation

Is this your nonprofit?

[Claim your profile for free](#)

[Learn about benefits](#)

Mission

This organization has not provided GuideStar with a mission statement.

Ruling year

2013

Principal Officer

Delice Coffey

Main address

1110 Scholastic Cir
Durham, NC 27713 United States

EIN

56-2220734

Subject area

Mental health care

NTEE code

Mental Health Treatment (F30)

IRS filing requirement

This organization is required to file an IRS Form 990-N.

Tax forms

[Show Forms 990](#)



[< Back to Search Results](#)

The D Coffey Foundation For Athletics & Education

(Helping People Help Themselves)

EIN: 56-2220734 | Durham, NC, United States

[> Other Names](#)

Form 990-N (e-Postcard) ⓘ

Organizations who have filed a 990-N (e-Postcard) annual electronic notice. Most small organizations that receive less than \$50,000 fall into this category.

[> Tax Year 2021 Form 990-N \(e-Postcard\)](#)

Tax Period:

2021 (01/01/2021 - 12/31/2021)

EIN:

56-2220734

Legal Name (Doing Business as):

The D Coffey Foundation For Athletics & Education

Mailing Address:

1110 SCHOLASTIC CIR
DURHAM, NC 27713
United States

Principal Officer's Name and Address:

Delice Coffey

1110 SCHOLASTIC CIR
DURHAM, NC 27713
United States

Gross receipts not greater than:
\$50,000

Organization has terminated:
No

Website URL:
DrDCoffey.com/Foundation

> **Tax Year 2020 Form 990-N (e-Postcard)**

> **Tax Year 2019 Form 990-N (e-Postcard)**

> **Tax Year 2018 Form 990-N (e-Postcard)**

> **Tax Year 2017 Form 990-N (e-Postcard)**

> **Tax Year 2015 Form 990-N (e-Postcard)**

> **Tax Year 2014 Form 990-N (e-Postcard)**

> **Tax Year 2013 Form 990-N (e-Postcard)**

> **Tax Year 2012 Form 990-N (e-Postcard)**

> **Tax Year 2010 Form 990-N (e-Postcard)**

Contact

www.linkedin.com/in/johnqtillman
(LinkedIn)

Top Skills

Business Coaching & Consulting
Management Consulting
Strategic Analysis

Certifications

Licensed Instructor, Business & Marketing
Certified Economic Development Finance Professional

Honors-Awards

United States Olympian
Minority Entrepreneur of the Year

John Tillman, MBA

Founder and Chief Executive Officer, Goodlife Coaching & Personal Development, Inc.

Monroe, North Carolina, United States

Summary

PROFILE

John Tillman is a visionary business executive with a successful track record of starting, growing, and guiding companies to leadership positions in their industries. His passion is helping individuals and organizations accelerate their success and achieve their full potential.

With an initial investment of only \$7,000, John built an enterprise that grossed over \$10 Million per year while providing life enhancing services to youth, adolescents and families throughout North Carolina. His educational and behavioral healthcare services company became an industry leader by exceeding customers' expectations, staying on the cutting edge of innovation in clinical and business best practices, and creating a "can-do", team-oriented corporate culture".

With more than 20 years of progressive business experience in training, marketing, human services, and economic development, John now applies his cumulative experience, knowledge and skills to assist entrepreneurs, executives and not-for-profit managers to achieve rapid short-term results as well as sustainable improvements to their overall business model and strategy.

KEY SKILLS AREAS

Strategic Planning

Community Economic Development

Marketing & Business Plan Development

Educational Service Delivery & Behavioral Healthcare Management

High Impact Coaching for Executives, Entrepreneurs & Business Managers

Consulting Focusing on Rapid Results & Long Term Sustainable Improvements

Experience

Goodlife Coaching & Personal Development, Inc.

Chief Executive Officer

April 2021 - Present (1 year 8 months)

Innovative start-up using technology to enhance delivery of education, coaching and therapeutic services. Promoting programs that address the specific and comprehensive needs of underserved and targeted populations.

Capital Asset Recovery of the Carolinas, Inc.

Chief Executive Officer

July 2014 - January 2021 (6 years 7 months)

Monroe, North Carolina

Provide strategic leadership to a multi-disciplinary team of professionals committed to researching, recovering and returning lost, displaced and otherwise unclaimed assets to their rightful owners.

Momentum Marketing / Strategic Business Solutions

President & Sr. Consultant

January 2010 - June 2014 (4 years 6 months)

Atlanta, Georgia Area & Charlotte, NC

Provide management consulting and advisory services to entrepreneurs, executives, and business leaders aiding them to secure required resources, enhance operational efficiency, and ensure sustainable growth and profitability.

Provide business management services for authors, motivational speakers and seminar/workshop facilitators.

EXCEL Personal Development, Inc.

Chief Executive Officer

April 1998 - December 2009 (11 years 9 months)

Turned a \$7,000 initial investment into a \$10 Million per year enterprise that assisted thousands of individuals to live healthier, happier lives.

Founded the company to address the educational and behavioral healthcare needs of youth, adolescents, adults and families in central and western North Carolina. Grew the company into an industry leader with 13 offices covering

two-thirds of the State and employing more than 400 educators and mental health professionals.

Successfully negotiated contractual agreements and partnerships with State agencies and local governmental entities. Led the company through numerous industry reforms, including privatization of public health services, national accreditation, changes in reimbursement rates and structures, and intensive auditing of services, all while maintaining high customer satisfaction.

Earned honors for leadership and corporate citizenship including Entrepreneur of the Year by the local Chamber of Commerce.

Monroe - Union County Community Development Corporation Executive Director

May 1995 - June 1999 (4 years 2 months)

Monroe, North Carolina

Improved the quality of life for hundreds of low and moderate income citizens of Union County, NC through housing development, home ownership counseling and assistance, business development, consumer counseling, job training and self-improvement seminars.

Partnered with First Union National Bank to acquire and convert 22 units of dilapidated housing into quality refurbished homes for first-time home buyers. Leveraged \$1,000,000 for construction costs and down payment assistance. Successfully wrote grant proposals that increased funding for Monroe - Union County CDC by 85% during first year as Executive Director. Doubled housing production during second year as Executive Director. Expanded services to include community education, and commercial/business development activities.

Increased the organization's visibility through networking and presentations to business and civic leaders, local government officials, and private and governmental funding organizations.

INROADS

Staff Specialist

1990 - 1994 (4 years)

Developed and placed talented minority youth in business and industry and prepared them for corporate and community leadership. Provided

professional training, academic enrichment, personal counseling, recruitment and placement.

USATF

1992 OLYMPIAN, TRIPLE JUMPER

1985 - 1992 (7 years)

Education

The University of Texas at Austin

MBA, Business Management, Entrepreneurship · (1987 - 1989)

University of Tennessee-Knoxville

B.S., Business Admin, Marketing & Psychology · (1984 - 1987)

**The D. Coffey Foundation for Athletics & Education
Social Emotional Readiness Program**

Expenses	Nov.-Dec.	Jan.	February	March	April-May	June	July	August	September	October	Nov.-Dec.	January	Feb.	Total
Curriculum Elementary - year	\$8,497		\$0	\$0	\$0				\$0	\$0	\$0	\$0		\$8,497
Program Director - 8 mts - (\$1000)	\$1,000		\$1,000	\$1,000	\$1,000				\$1,000	\$1,000	\$1,000	\$1,000		\$8,000
Executive Director - 8 mts (\$1125)	\$1,125		\$1,125	\$1,125	\$1,125				\$1,125	\$1,125	\$1,125	\$1,125		\$9,000
Rent - (Cost-\$3,600-6 mts)	\$0		\$0	\$0	\$0				\$0	\$0	\$0	\$0		\$0
Utilities, lights, internet (Cost-\$300)	\$0		\$300	\$250	\$250				\$250	\$250	\$250	\$0		\$1,550
Student Supplies	\$350		\$100	\$100	\$100				\$100	\$100	\$100	\$0		\$950
Liability Insurance yearly	\$143		\$0	\$0	\$0				\$0	\$0	\$0	\$0		\$143
Accounting - 7 mts. \$350 mtlly	\$0		\$350	\$350	\$350				\$350	\$350	\$350	\$350		\$2,450
Marketing & Advertising 3 months	\$200		\$100	\$0	\$0				\$0	\$0	\$0	\$0		\$300
8 Student Teachers - Semester 1 - \$10 hrly	\$0		\$1,920	\$1,920	\$1,920				\$0	\$0	\$0	\$0		\$5,760
8 Student Teachers - Semester 2 - \$10 hrly	\$0		\$0	\$0	\$0				\$1,920	\$1,920	\$1,920	\$0		\$5,760
Program Assistant (8 months) - \$10 hrly	\$240		\$240	\$240	\$240				\$240	\$240	\$240	\$240		\$1,920
Office Supplies	\$250		\$50	\$50	\$50				\$50	\$50	\$50	\$0		\$550
Transportation	\$0		\$926	\$926	\$926				\$926	\$926	\$926	\$0		\$5,556
Cleaning Crew - \$10 hrly.	\$0		\$60	\$60	\$60				\$60	\$60	\$60	\$0		\$360
Snacks	\$0		\$333	\$333	\$333				\$333	\$333	\$333	\$0		\$1,998
Legal Fees \$400 per hour	\$2,000		\$0	\$0	\$0				\$0	\$0	\$0	\$0		\$2,000
Computer	\$0		\$0	\$0	\$0				\$0	\$0	\$0	\$0		\$0
Printer	\$0		\$0	\$0	\$0				\$0	\$0	\$0	\$0		\$0
Miscellaneous	\$500		\$150	\$150	\$150				\$150	\$150	\$150	\$0		\$1,400
Private Facebook Group - \$97 yrly	\$0		\$0	\$0	\$0				\$0	\$0	\$0	\$0		\$0
Emergency Contact Number - \$100 per call	\$0		\$0	\$0	\$0				\$0	\$0	\$0	\$0		\$0
Live Virtual Session \$150	\$0		\$0	\$0	\$0				\$0	\$0	\$0	\$0		\$0
Tutoring - \$35 per hour	\$0		\$0	\$0	\$0				\$0	\$0	\$0	\$0		\$0
Mental Health - \$250 per hour	\$0		\$0	\$0	\$0				\$0	\$0	\$0	\$0		\$0
Total Expenses	\$14,305	\$0	\$6,654	\$6,504	\$6,504	\$0	\$0	\$0	\$6,504	\$6,504	\$6,504	\$2,715	\$0	\$56,194

This page has been intentionally left blank.

GRANT AGREEMENT

Between

THE TOWN OF MINERAL SPRINGS, North Carolina
and
THE D. COFFEY FOUNDATION FOR ATHLETICS AND EDUCATION

Article I. Overview.

Section 1.1. Parties. The parties to this agreement are the Town of Mineral Springs, North Carolina, a body politic and political subdivision of the State of North Carolina (“TOWN”) and The D. Coffey Foundation for Athletics and Education, a North Carolina non-profit corporation [“RECIPIENT”].

Section 1.2. Source of Funding. This Agreement is funded by Grant project Ordinance #O-2022-05 adopted by the Mineral Springs Town Council on November 10, 2022.

Section 1.3. Purpose. The purpose of this Agreement is to establish the terms and conditions for a grant award allocated to the RECIPIENT from the TOWN.

Section 1.4. Term. This Agreement shall govern the performance of the parties for the period November 10, 2022 (the “Effective Date”) through March 31, 2024 (“Expiration Date”), unless earlier terminated by either party in accordance with the terms of this Agreement (“Agreement Term”).

Article II. Scope of Funded Activities.

Section 2.1. Scope of Services. RECIPIENT shall perform all activities described in the scope of activities, attached hereto as Exhibit A (Approved Activities).

Section 2.2. Budget. RECIPIENT shall perform the Approved Activities in accordance with the program budget as approved by the TOWN and attached hereto as Exhibit B (Approved Budget).

Section 2.3. Prior Approval for Changes. RECIPIENT may not make any changes, directly or indirectly, to program design, Approved Activities, or Approved Budget without the prior written approval of TOWN. Monthly variations in demand-based line items (e.g., supplies, utilities, snacks) are permissible provided those expenditures do not exceed total project budget amounts.

Article III. Compensation.

Section 3.1. Payment of Funds. TOWN agrees to provide funds to the RECIPIENT in accordance with the Approved Budget and for the performance of the Approved Activities under this Agreement in an amount not to exceed \$56,194 (“Total Agreement Funds”). The amount of Total Agreement Funds, however, is subject to adjustment by the TOWN if a substantial change is made in the Approved Activities that affects this Agreement or if this Agreement is terminated prior to the expiration of the Agreement. Program funds shall not be expended prior to the Effective Date or following the earlier of the Expiration Date or the last day of the Agreement Term. Costs incurred shall only be as necessary and allowable to carry out the purposes and activities of the Approved Activities and may not exceed the maximum limits set in the Approved Budget. Expenses charged against the Total Agreement Funds shall be incurred in accordance with this Agreement.

Section 3.2. Payment Schedule. TOWN shall make payments to the RECIPIENT on the following schedule provided all prior invoices and reports described in Section 3.3 have been made:

Report Date	Reporting Period Covered	Payment Date	Payment Amount
N/A	N/A	11/15/2022	\$14,305.00
01/20/2023	11/15/2022-12/31/2022	02/01/2023	\$6,654.00

02/20/2023	Invoice only	03/01/2023	\$6,504.00
03/20/2023	01/01/2023-02/28/2023	04/01/2023	\$6,504.00
06/20/2023	03/01/2023-05/30/2023	09/01/2023	\$6,504.00
09/20/2023	Invoice only	10/01/2023	\$6,504.00
10/20/2023	09/01/2023-09/30/2023	11/01/2023	\$6,504.00
02/20/2024	10/01/2023-01/31/2023	03/20/2024	\$2,715.00*

*subject to final reconciliation

Section 3.3. Reports and Invoices. On or before the twentieth (20th) day of each of the months of January 2023, March 2023, June 2023, and October 2023, RECIPIENT shall submit to the TOWN’s Finance Officer either by US Mail or by email a financial report detailing the activities for the period indicated in the table in Section 3.2 and an invoice for the upcoming payment as shown in the table under “Payment Amount”, setting forth actual expenditures made by RECIPIENT for the period in accordance with this Agreement. On or before the twentieth (20th) day of February 2023 and September 2023 RECIPIENT shall submit only an invoice for the upcoming payment as shown in the table under “Payment Amount”. The TOWN’s Finance Officer shall evaluate each report and/or invoice for compliance with this agreement and if RECIPIENT has been found to be in compliance the TOWN’s Finance Officer shall disburse the next payment on the schedule presented in Section 3.2 to RECIPIENT by check mailed prior to the fifth calendar day after the Payment Date shown in the table in Section 3.2. On or before the twentieth (20th) day of February 2024 RECIPIENT shall submit a Final Report and reconciliation of all project activities and expenditures. The amount of the Final Payment shall be calculated by subtracting from the amount of the Total Agreement Funds the total of all actual expenditures made by RECIPIENT over the duration of the project. The TOWN’s Finance Officer shall review the final report and disburse any Final Payment to RECIPIENT within 30 days of receipt of the Final Report.

Article IV. Financial Accountability and Grant Administration.

Section 4.1. Financial Management. RECIPIENT shall maintain a financial management system and financial records related to all transactions with funds received pursuant to this Agreement. RECIPIENT shall maintain detailed, itemized documentation and other necessary records of all income received and expenses incurred pursuant to this Agreement.

Section 4.2. Limitations on Expenditures. TOWN shall only approve documented expenditures incurred by RECIPIENT during the Agreement Term that are: (i) in conformity with the program budget attached hereto as Exhibit B, (ii) reasonable and necessary to carry out the scope of Approved Activities described in Exhibit A; (iii) documented by contracts, invoices, vouchers, or other evidence of liability consistent with the established TOWN and RECIPIENT procedures; and (iv) incurred in accordance with all applicable requirements for the expenditure of funds payable under this Agreement. TOWN may not reimburse or otherwise compensate RECIPIENT for any expenditures incurred or services provided prior to the Effective Date or following the earlier of the expiration or termination of this Agreement.

Section 4.3. Closeout. Following RECIPIENT’s final report under this Agreement, TOWN shall reconcile all prior payments to and expenditures by RECIPIENT and shall make final payment in an amount determined by this reconciliation as specified in Section 3.3 but in no event greater than the balance of the original project budget that remains unpaid unless TOWN has previously approved an increase in any budget amount under the provisions of Section 2.3. In consideration of the execution of this Agreement by TOWN, RECIPIENT agrees that acceptance of final payment from TOWN will constitute an agreement by RECIPIENT to release and forever discharge TOWN, its agents, employees, officers, representatives, affiliates, successors and assigns from any and all claims, demands, damages, liabilities, actions, causes of action or suits of any nature whatsoever, which RECIPIENT has at the time of acceptance of final payment or may thereafter have, arising out of, in connection with or in any way relating to any and all injuries and damages of any kind as a result of or in any way relating to this Agreement. The RECIPIENT’s obligations to TOWN under this Agreement shall not terminate until all closeout requirements are completed to the satisfaction of TOWN. Such requirements shall include submitting final reports to TOWN and providing any closeout-related information requested by TOWN by the deadlines specified by TOWN. This provision shall survive the expiration or termination of this Agreement.

Article V. Compliance with Grant Agreement and Applicable Laws.

Section 5.1. Equal Opportunity & Other Requirements. RECIPIENT shall operate under nondiscrimination practices consistent with the requirements in this section.

Civil Rights Laws. RECIPIENT shall comply with Title VI of the Civil Rights Act of 1964 (42 U.S.C. §§ 2000d *et seq.*), which prohibits discrimination on the basis of race, color, or national origin.

Disability Protections. RECIPIENT shall comply with section 504 of the Rehabilitation Act of 1973 (29 U.S.C. 794), which prohibits discrimination on the basis of disability under any program or activity.

Age Discrimination. RECIPIENT shall comply with the Age Discrimination Act of 1975 (42 U.S.C. §§ 6101 *et seq.*) which prohibits discrimination on the basis of age in programs or activities.

Americans with Disabilities Act. RECIPIENT shall comply with Title II of the Americans with Disabilities Act of 1990 (42 U.S.C. §§ 12101 *et seq.*), which prohibits discrimination on the basis of disability under programs, activities, and services provided or made available by state and local governments or instrumentalities or agencies thereto.

Section 5.2. Licenses, Certifications, Permits, Accreditation. RECIPIENT shall obtain and keep current any license, certification, permit, or accreditation required by federal, state, or local law and shall submit to TOWN proof of any licensure, certification, permit, or accreditation upon request.

Article VI. Default and Termination.

Section 6.1. Termination for Cause. TOWN may terminate this Agreement for cause after three days written notice. Cause may include misuse of funds, fraud, lack of compliance with applicable rules, laws and regulations, failure to perform on time, or failure to comply with any of the requirements of this Agreement.

Section 6.2. Termination Without Cause. TOWN may terminate this Agreement for any reason, in its sole discretion, by providing RECIPIENT with thirty (30) days prior written notice.

Section 6.3. Termination by Mutual Agreement. TOWN and RECIPIENT may agree to terminate this Agreement for their mutual convenience through a written amendment to this Agreement. The amendment will state the effective date of the termination and the procedures for proper closeout of the Agreement.

Section 6.4. Termination Procedures. If this Agreement is terminated, RECIPIENT may not incur new obligations for the terminated portion of the Agreement after RECIPIENT has received the notification of termination. RECIPIENT must cancel as many outstanding obligations as possible. Costs incurred after receipt of the termination notice will be disallowed. RECIPIENT shall not be relieved of liability to TOWN because of any breach of Agreement by RECIPIENT. TOWN may, to the extent authorized by law, withhold payments to RECIPIENT for the purpose of set-off until the exact amount of damages due TOWN from RECIPIENT is determined.

Article VII. General Conditions.

Section 7.1. Indemnification. To the extent permitted by law, RECIPIENT agrees to indemnify and hold harmless TOWN, and any of its officers, agents and employees from any claims of third parties arising out of any act or omission of RECIPIENT in connection with the performance of this Agreement.

Section 7.2. Insurance. RECIPIENT must maintain insurance policies with minimum limits as follows:

Commercial General Liability Insurance: RECIPIENT shall provide commercial general liability insurance on a comprehensive broad form on an occurrence basis with a minimum combined single limit of \$1,000,000.00 for each occurrence.

Automobile Liability Insurance: RECIPIENT shall provide automobile liability insurance with a combined single limit of \$500,000.00 for bodily injury and property damage; a limit of \$500,000.00 for uninsured/under insured motorist coverage; and a limit of \$2,000.00 for medical payment coverage. RECIPIENT shall provide this insurance for all automobiles that are: (A) owned by RECIPIENT and used in the performance of this agreement; (B) hired by RECIPIENT and used in the performance of this agreement; and (C) owned by RECIPIENT's employees and volunteers and used in performance of this agreement ("non-owned vehicle insurance"). Non-owned vehicle insurance protects employers when employees use their personal vehicles for work purposes. Non-owned vehicle insurance supplements, but does not replace, the car-owner's liability insurance. RECIPIENT is not required to provide and maintain automobile liability insurance on any vehicle – owned, hired, or non-owned -- unless the vehicle is used in the performance of this agreement.

The insurer must provide TOWN with a Certificate of Insurance reflecting the coverages required in this Section. All Certificates of Insurance shall reflect thirty (30) days written notice by the insurer in the event of cancellation, reduction, or other modification of coverage. In addition to this notice requirement, RECIPIENT must provide TOWN prompt written notice of cancellation, reduction, or material modification of coverage of insurance. If RECIPIENT fails to provide such notice, the RECIPIENT assumes sole responsibility for all losses incurred by TOWN for which insurance would have provided coverage. The insurance policies must remain in effect during the term of this Agreement.

RECIPIENT shall name TOWN as an additional insured and it is required that coverage be placed with an "A" rated insurance company acceptable to TOWN. If RECIPIENT fails at any time to maintain and keep in force the required insurance, TOWN may cancel and terminate the Agreement without notice.

Section 7.3. Venue and Jurisdiction. TOWN and RECIPIENT agree that they executed and performed this Agreement in UNION COUNTY, North Carolina. This Agreement will be governed by and construed in accordance with the laws of North Carolina. The exclusive forum and venue for all actions arising out of this Agreement is the appropriate division of the North Carolina General Court of Justice in UNION COUNTY. Such actions may not be commenced in, nor removed to, federal court unless required by law.

Section 7.4. Nonwaiver. No action or failure to act by TOWN constitutes a waiver of any of its rights or remedies that arise out of this Agreement, nor shall such action or failure to act constitute approval of or acquiescence in a breach of this Agreement, except as specifically agreed in writing.

Section 7.5. Limitation of TOWN Authority. Nothing contained in this Agreement may be deemed or construed to in any way stop, limit, or impair TOWN from exercising or performing any regulatory, policing, legislative, governmental, or other powers or functions.

Section 7.6. Severability. If any provision of this Agreement is determined to be unenforceable in a judicial proceeding, the remainder of this Agreement will remain in full force and effect to the extent permitted by law.

Section 7.7. Assignment. RECIPIENT may not assign or delegate any of its rights or duties that arise out of this Agreement without TOWN's prior written consent. Unless TOWN otherwise agrees in writing, RECIPIENT and all assigns are subject to all TOWN's defenses and are liable for all RECIPIENT's duties that arise from this Agreement and all TOWN's claims that arise from this Agreement.

Section 7.8. Integration. This Agreement contains the entire agreement between the parties pertaining to the subject matter of this Agreement. With respect to that subject matter, there are no promises, agreements, conditions, inducements, warranties, or understandings, written or oral, expressed, or implied, between the parties, other than as set forth or referenced in this Agreement.

Section 7.9. Notices. All notices and other communications required or permitted by this Agreement must be in writing and must be given either by personal delivery, approved carrier, email, or mail, addressed as follows:

- (a) If to the TOWN:
PO Box 600, Mineral Springs NC 28108
msncmayor@yahoo.com

(b) If to the RECIPIENT:
1110 Scholastic Cir, Durham NC 27713
delicecoffey@gmail.com

IN WITNESS WHEREOF, the parties have caused this Agreement to be signed by their duly constituted legal representatives on this the 10th day of November, 2022 and is effective as of the Effective Date.

For the TOWN OF MINERAL SPRINGS (“TOWN”):

Frederick Becker III, Mayor

Attest:

Vicky A. Brooks, CMC, Town Clerk

For D. Coffey Foundation for Athletics and Education (“RECIPIENT”):

Dr. Delice Coffey, President

This instrument has been preaudited
as required by the Local Government
Budget and Fiscal Control Act.

Frederick Becker III, Finance Officer

Date

Exhibit A: Approved Activities

The D. Coffey Foundation for Athletics & Education has been a nationally recognized 501(c)(3) organization since 2013. Our focus is quality education for all, especially those who need a helping hand. We are requesting grant funding from the Town of Mineral Springs in an amount not to exceed \$56,194 to implement a program we are calling "Social-Emotional Readiness" in Mineral Springs to serve a targeted enrollment of fifty Mineral Springs children in Kindergarten through Fifth Grade. This program is specifically designed to address recent well-documented negative effects on both social-emotional and academic development in school children as a result of the almost two-year-long disruption to their in-person learning environments and their overall social interactions resulting from the Covid-19 pandemic.

We have adopted the Social Emotional Learning curriculum called "Purposefull People" developed by CharacterStrong and have added tutoring and mental health to bring this first-to-market combination, which will yield more significant results to a curriculum already proven effective by research. The Social-Emotional Readiness program will be housed in a modern multi-purpose facility in Mineral Springs, staffed with eight students from Wingate University who are studying to pursue careers in teaching, and overseen by a Program Director on site for every session. Student supplies, snacks, and curriculum materials will be provided, and transportation will be available.

The program will run for twelve weeks, February-May and September-December. We will meet with the students after school three times a week for two hours. Each week there will be a specific SEL topic with handouts, videos, and face-to-face interactions with student teachers. Students who need tutoring and mental health services will be assessed individually and provided with those services as needed. We will have a Facebook group where the students can communicate and ask questions daily. There will be an emergency number for the mental health of any student in crisis, and a monthly live virtual session with the students, Executive Director, Program Director, and student teachers to celebrate the student wins, big and small. What we know for sure is that what gets celebrated gets repeated!

Exhibit B: Approved Budget

<u>REVENUES</u>		Total Revenue
Town of Mineral Springs Grant Project Ordinance #O-2022-05		\$56,194
<u>Budget Cost Categories</u>		Total Expenditures
	Description of Category	
1.	Curriculum	\$8,497
2.	Program Director	\$8,000
3.	Executive Director	\$9,000
4.	Facilities	\$1,910
5.	Student Supplies	\$950
6.	Liability Insurance	\$143
7.	Accounting	\$2,450
8.	Teaching Personnel	\$11,520
9.	Support Personnel	\$1,920
10.	Office Supplies	\$550
11.	Student Transportation	\$5,556
12.	Student Snacks	\$1,998
13.	Legal Fees	\$2,000
14.	Marketing & Advertising	\$300
15.	Miscellaneous	\$1,400
16.	Total Costs: Mineral Springs Grant Funds	\$56,194
<u>MUST EQUAL REVENUE TOTAL ABOVE</u>		

STATE OF NORTH CAROLINA
TOWN OF MINERAL SPRINGS

**PROJECT ORDINANCE AUTHORIZING A GRANT TO THE D. COFFEY
FOUNDATION FOR ATHLETICS AND EDUCATION FOR A SOCIAL-
EMOTIONAL READINESS PROGRAM**

O-2022-05

Pursuant to section 13.2 of Chapter 159 of the General Statutes of North Carolina, the following project ordinance is hereby adopted:

Section 1: The project involves implementation of a program called “Social-Emotional Readiness” by the D. Coffey Foundation for Athletics and Education, to be funded by a grant from the Town of Mineral Springs in an amount not to exceed fifty-six thousand one hundred ninety-four dollars (\$56,194.00).

The project consists of an after-school program combining social-emotional learning, mental health, and academic tutoring for Mineral Springs children in Kindergarten through Fifth Grade. The program will run from February 2023 through December 2023 in two semesters of twelve weeks each with a targeted enrollment of fifty students per semester. A grant agreement for this program was approved by the Mineral Springs Town Council on November 10, 2022.

Section 2: It is estimated that the following revenues will be available to complete those projects described in section 3:

General Fund Balance	\$56,194.00
Total	\$56,194.00

Section 3: The following amounts are appropriated for the Social-Emotional Readiness Project fund:

Project implementation	\$56,194.00
Total	\$56,194.00

Section 4: The Finance Officer is authorized to make periodic payments to the D. Coffey Foundation for Athletics and Education for implementation of the program based on the reporting and payment schedule set forth in the agreement between the town and the foundation.

Section 5: The Finance Officer is hereby directed to maintain within the Social-Emotional Readiness Project Fund sufficient detailed accounting records for the project authorized.

Section 6: The Finance Officer is directed to report the financial activity of the Social-Emotional Readiness Project Fund as a part of each regular monthly Mineral Springs Finance Report in any month that such activity takes place.

Section 7: The Finance Officer is authorized to transfer funds as required, not to exceed the total amount authorized by this ordinance, from the General Fund balance into the Social-Emotional Readiness Project Fund.

Section 8: Copies of this Social-Emotional Readiness Project Ordinance shall be filed with the Town Clerk and the Finance Officer.

ADOPTED this the 10th day of November, 2022.

Frederick Becker III, Mayor

Attest:

Vicky A. Brooks, Clerk

DRAFT

2023 Mineral Springs Holiday Schedule

The following public holidays are established for the Town of Mineral Springs employees. The town hall will officially be closed on the days shown below.

Monday, January 2, 2023	New Year's Day
Monday, January 16, 2023	Birthday of Martin Luther King, Jr.
Monday, February 20, 2023	Washington's Birthday (aka President's Day)
Monday, April 10, 2023	Easter Monday
Monday, May 29, 2023	Memorial Day
Monday, June 19, 2023	Juneteenth National Independence Day
Tuesday, July 4, 2023	Independence Day
Monday, September 4, 2023	Labor Day
Monday, October 9, 2023	Columbus Day
Friday, November 10, 2023	Veterans Day
Thursday, November 23, 2023	Thanksgiving Day
Friday, November 24, 2023	Thanksgiving Day Holiday
Friday, December 22, 2023 – Friday, December 29, 2023	Christmas Holiday Week
Monday, January 1, 2024	New Year's Day

Town Council review on November 10, 2022